

RUIDE

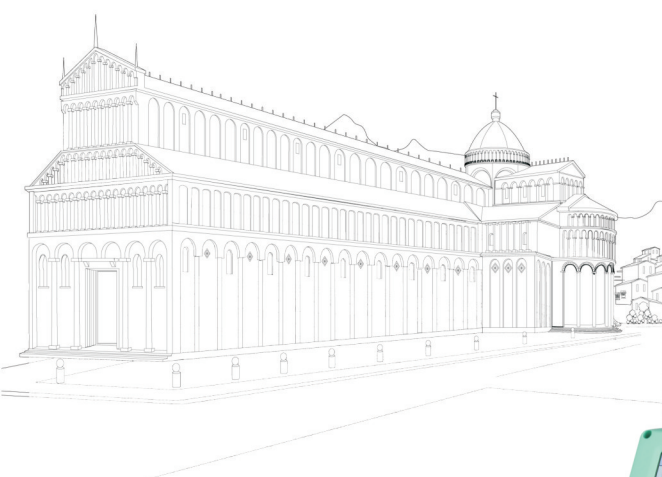

USER MANUAL

RTS-860R SERIES

FORWORDS

Congratulations on purchasing RUIDE Total Station RTS-860R series.

This manual will give a detailed and complete instruction about this total station. Please read it carefully before use.

CONTENT

| | |
|---|----|
| FORWORDS | 1 |
| FEATURES | 5 |
| PRECAUTIONS | 6 |
| 1. BRIEF INTRODUCTION | 7 |
| 1.1 Appearance | 7 |
| 1.2 Unpacking and Storing the Total Station | 9 |
| 1.3 Instrument Setup | 9 |
| 1.4 Battery: Information, and Recharging | 12 |
| 1.5 Reflectors | 13 |
| 1.6 Mounting and Dismounting Instrument from Tribrach | 13 |
| 1.7 Eyepiece Adjustment and Collimating Objects | 14 |
| 1.8 Powering ON/OFF | 14 |
| 2. OPERATION | 16 |
| 2.1 Operation Keys | 16 |
| 2.2 Symbols..... | 17 |
| 3. JOB MANAGEMENT | 19 |
| 3.1 Create New Job..... | 19 |
| 3.2 Open Job | 19 |
| 3.3 Delete Job | 20 |
| 3.4 Save As | 20 |
| 3.5 Recycle Bin..... | 20 |
| 3.6 Information | 21 |
| 3.7 Import..... | 21 |
| 3.8 Export..... | 22 |
| 3.9 About..... | 22 |
| 4. DATA MANAGEMENT | 23 |
| 4.1 Raw Data..... | 23 |
| 4.2 XYZ Data | 23 |
| 4.3 Code Data | 24 |
| 4.4 Graphics | 25 |
| 5. COGO | 26 |
| 5.1 Calculator | 26 |
| 5.2 Calculate XYZ..... | 26 |
| 5.3 Inverse | 27 |
| 5.4 Area & Perimeter | 27 |
| 5.5 Pt-Line Inverse | 28 |
| 5.6 2 Points Inverse | 29 |
| 5.7 4 Points Inverse | 30 |

| | |
|--------------------------------------|-----------|
| 5.8 Volume | 31 |
| 5.9 Unit | 32 |
| 6. SET | 33 |
| 6.1 Unit Setting..... | 33 |
| 6.2 Angle Setting | 34 |
| 6.3 Distance Setting | 34 |
| 6.4 NEZ Setting | 35 |
| 6.5 RS232 Communication Setting..... | 35 |
| 6.6 Bluetooth | 36 |
| 6.7 Power Management | 36 |
| 6.8 Other | 37 |
| 6.9 Upgrade..... | 37 |
| 6.10 Format..... | 38 |
| 6.11 Reset | 38 |
| 7. ADJUSTMENT | 39 |
| 7.1 Compensator | 39 |
| 7.2 V0 Adjustment..... | 39 |
| 7.3 Additive Constant..... | 41 |
| 7.4 LCD Adjust | 42 |
| 8. MEASUREMENT | 43 |
| 8.1 Angle | 43 |
| 8.2 Distance | 44 |
| 8.3 Coordinates..... | 44 |
| 9. STATION | 46 |
| 9.1 Knownpt..... | 46 |
| 9.2 Stn Ht | 47 |
| 9.3 Bs Check | 47 |
| 9.4 Resection..... | 48 |
| 10. COLLECT | 49 |
| 10.1 Pt Measure | 49 |
| 10.2 Dist.Offset | 50 |
| 10.3 Angle Pt | 51 |
| 10.4 Column Center | 52 |
| 10.5 MLM..... | 53 |
| 10.6 Line & Extend Pt | 54 |
| 10.7 Line & AngPt | 55 |
| 11. STAKE OUT | 56 |
| 11.1 Pt SO | 56 |
| 11.2 Ang & Dist SO | 57 |
| 11.3 Alignment SO | 58 |

| | |
|---|-----------|
| 11.4 Straight Reference Line SO | 58 |
| 12. ROAD | 60 |
| 12.1 Select Road | 60 |
| 12.2 H Alignment | 60 |
| 12.3 V Alignment | 63 |
| 12.4 Road SO | 64 |
| 12.5 Road XYZ | 65 |
| 13. CHECK AND ADJUSTMENT | 66 |
| 13.1 Plate Vial | 66 |
| 13.2 Circular Vial | 67 |
| 13.3 Compensator 0 Offset Adjustment | 67 |
| 13.4 Inclination of Reticle | 67 |
| 13.7 Adjustment of Vertical Index Difference (i Angle) and Setting Vertical Index 0 ... | 69 |
| 13.8 Optical Plummet | 69 |
| 13.9 Laser Plummet | 70 |
| 13.10 Instrument Constant (K) | 71 |
| 13.11 Parallelity between Sight Line and Emitting Photoelectronic Axis | 71 |
| 13.12 Tribrach Leveling Screw | 72 |
| 13.13 Related Parts for Reflector | 72 |
| 14. SPECIFICATION | 73 |
| 15. SAFETY GUIDE | 75 |
| 15.1 Internal Distance Meter (Visible Laser) | 75 |
| 15.2 Laser Plummet | 76 |
| APPEDIX A: DATA FORMAT | 78 |

FEATURES

1. Abundant Functions

This series covers various surveying programs as well as functions of data storage and parameter settings. It is capable for various kinds of professional surveying and engineering measurements.

2. Easy and Quick Operation on Touch Screen

This series employs advanced technology of touch screen, making the operation easy and quick. You can use the touch screen and keyboard at the same time, which accelerate the operation speed.

3. More Choices on Data Transfer

Supportable to SD card, U-Disk, and USB to connect to the computer. Moreover, Bluetooth® is available to connect with PDA.

4. Automation of Data Collect

Auto data collect program can record the measurement and coordinates data automatically, and transfer the data with the computer.

5. Advanced Hardware Configuration

A better design is put on the body and internal structure to improve the performance and water and dust proof. Additionally, it employs various advanced technology on super far reflectorless measuring range, absolute encoding angle measurement, precise dual-axis compensator, and high-strength body.

6. Specific Survey Programs

Besides of the common measure modes, (angle, distance, coordinates measurements), RTS-860 series provides several specific survey programs like road design, COGO, etc, meeting various needs for professional measurements. You can also customize your own programs on your need.

7. User-friendly Operation Interface

The operation menu is well designed to carter the operation practices of most surveyors.

PRECAUTIONS

1. Do not collimate the objective lens directly to the sunlight without a filter.
2. Do not store the instrument in extremely high or low temperature, in order to avoid the sudden or great change of temperature.
3. When the instrument is not in use, store it in the case and avoid shock, dust and humidity.
4. If there is great difference between the temperature in work site and that in store place, you should leave the instrument in the case till it adapts to the temperature of environment.
5. If the instrument has not been used for a long time, you should remove the battery for separate storage. The battery should be charged once a month.
6. When transporting the instrument should be placed in its carrying case, it is recommended that cushioned material should be used around the case for support.
7. For less vibration and better accuracy, the instrument should be set up on a wooden tripod rather than an aluminum tripod.
8. Clean exposed optical parts with degreased cotton or less tissue only!
9. Clean the instrument surface with a woolen cloth after use. If it gets wet, dry it immediately.
10. Before opening, inspect the power, functions and indications of the instrument as well as its initial setting and correction parameters.
11. Unless the user is a maintenance specialist, do not attempt to disassemble the instrument by yourself even if you find the instrument abnormal.
12. Do not shoot the laser at people's eyes. Do not stare at the laser emitter.

1. BRIEF INTRODUCTION

1.1 Appearance



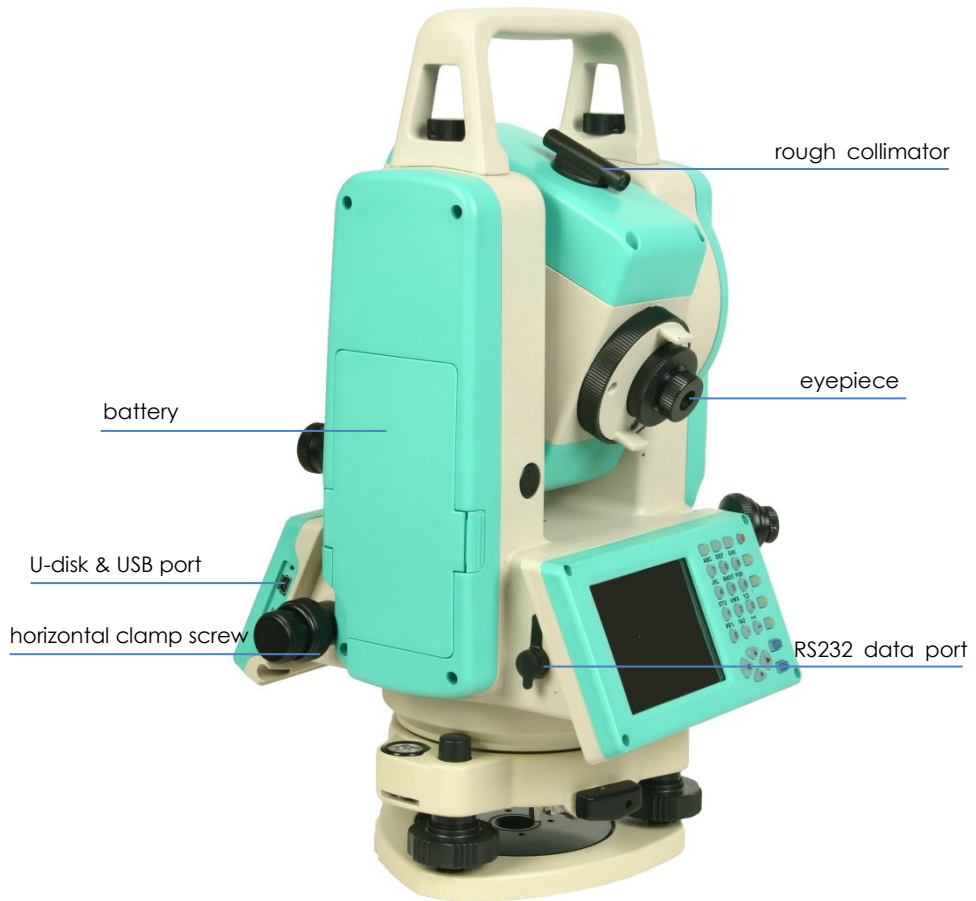

1.2 Unpacking and Storing the Total Station

Unpacking

Lay down the case lightly with the cover upward. Unlock the case, and take out the instrument.

Storage of Instrument

Cover the telescope cap, place the instrument into the case with the vertical clamp screw and circular vial upwards (objective lens towards tribrach), and slightly tighten the vertical clamp screw and lock the case.

1.3 Instrument Setup

Mount the instrument to the tripod. Level and center the instrument precisely to ensure the best performance.

Operation Reference

1. Leveling and Centering the Instrument by plumb bob

1) Setting up the tripod

① First, extend the extension legs to suitable length, make the tripod head parallel to the ground and tighten the screws.

② Make the centre of the tripod and the occupied point approximately on the same plumb line.

③ Step on the tripod to make sure if it is well stationed on the ground.

2) Attaching the instrument on the tripod

Place the instrument carefully on the tripod head and slide the instrument by loosening the tripod screw. If the plumb bob is positioned right over the center of the point, slightly tighten the tripod.

3) Roughly leveling the instrument by using the circular vial

① Turn the leveling screw A and B to move the bubble in the circular vial, in which case the bubble is located on a line perpendicular to a line running through the centers of the two leveling screw being adjusted .

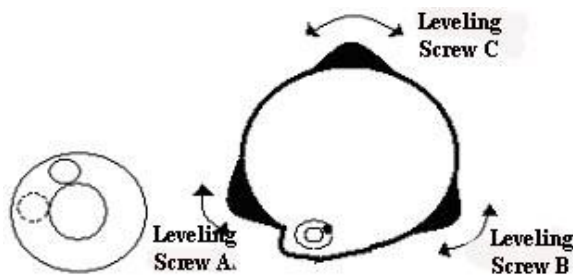

② Turn the leveling screw C to move the bubble to the center of the circular vial.

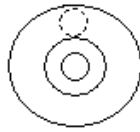

4) Precisely leveling by using the plate vial

① Rotate the instrument horizontally by loosening the Horizontal Clamp Screw and place the plate vial parallel to the line connecting leveling screw A and B, and then bring the bubble to the center of the plate vial by turning the leveling screws A and B.

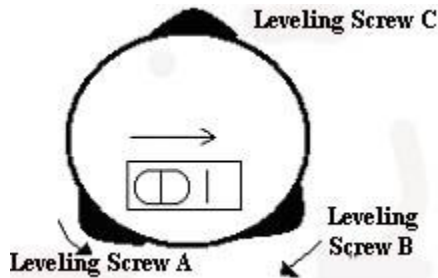

② Rotate the instrument 90° (100g) around its vertical axis and turn the remaining leveling screw or leveling C to center the bubble once more.

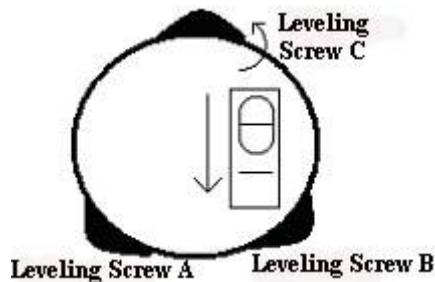

③ Repeat the steps ①② for each 90° (100g) rotation of the instrument and check whether the bubble is correctly centered in all directions.

2. Centering by using the optical plummet

1) Set tripod

Lift tripod to suitable height, ensure equal length of three legs, spread and make tripod head parallel to the ground, and place it right above the measurement station point. Prop up tripod on the ground and fix one leg.

2) Install instrument and collimate the point

Set instrument carefully on tripod, tighten the central connecting screw and adjust optical plummet to make the reticle distinctly. Hold the other two unfixed legs with both hands and adjust position of these two legs through observation of optical plummet. As it approximately aims at the station point, make all three

legs fixed on the ground. Adjust three leg screws of the instrument to make optical plummet collimate precisely to the station point.

3) Use circular vial to roughly level the instrument.

Adjust length of three legs of tripod; make the circular vial bubble of the instrument in the middle.

4) Use plate vial to level the instrument accurately.

① Rotate the instrument horizontally by loosening the Horizontal Clamp Screw and place the plate vial parallel to the line connecting leveling screw A and B, and then bring the bubble to the center of the plate vial by turning the leveling screws A and B.

② Rotate the instrument 90°, make it perpendicular to the connecting line of level screws A and B. Turn level screw C to make the bubble of the plate vial in the middle.

5) Precisely centering and leveling

Through observation of optical plummet, slightly loosen the central connecting screw and move the instrument evenly (Don't rotate the instrument), making the instrument precisely collimating to the station point. Then tighten the central connecting screw and level the instrument precisely again.

Repeat this operation till the instrument collimate precisely to the measurement station point.

3. Centering by laser plummet (optional)

1) Set up the tripod

Extend the legs to suitable length, make the tripod head roughly parallel to the ground and up to the station point. Fix one of the leg to the ground.

2) Mount the instrument and centering

Mount the instrument carefully on the tripod and tighten the screw under the head of the tripod. Turn on the laser plummet. Hold the two free legs which are not fixed to the ground and decide the position of the ground to fix according to the laser dot. When the laser dot is roughly on the station point, fix the 2 legs on the ground. Adjust the leveling screws on the total station tribrach until the laser dot is on the station point precisely.

3) Level the circular and plate vials as the instruction above.

4) Precisely centering and leveling the instrument

By observing the laser dot, slightly loosen the screw under the tripod head and move the instrument (not to rotate the instrument) until the laser dot is on the station point precisely. Tighten the screw and level the instrument again.

Repeat these steps until the instrument is precisely centered and leveled.

Tips

You can also level the instrument precisely by the E-bubble.

When the tilt is over $\pm 4'$, the system will enter to E-bubble adjustment interface.

- In E-bubble interface, you can check and set the dual-axis compensation.

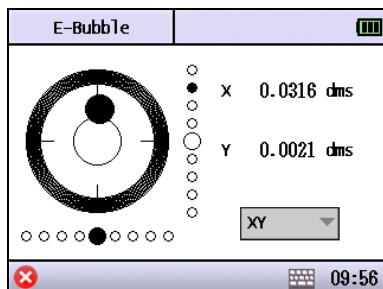

- ◆ X: Displays the compensating value on X direction
- ◆ Y: Displays the compensating value on Y direction.

1.4 Battery: Information, and Recharging

Battery Information

When the remaining battery is less than one grid, it means the battery is low, please stop your operation and change the battery as soon as possible.

Note

① The battery operating time will vary depending on the environmental conditions such as ambient temperature, charging time, the number of times of charging and discharging etc. It is recommended for safety to charge the battery beforehand or to prepare spare full charged batteries.

② The battery power remaining display shows the power level regarding the current measurement mode. The distance measurement mode consumes more power than angle measurement mode, so the power enough for the latter is not sure applicable for the previous one. Pay particular attention to this when switching angle measurement mode to distance measurement mode, because insufficient battery power might lead to interrupted operation.

- Before outdoor operation, battery power status should be well checked.

③ When the measurement mode is changed, the battery power would not immediately show the decrease or increase. The battery power indicating system shows the general status but not the instantaneous change of battery power.

Battery Recharging

☆ Battery should be recharged only with the charger packed with the instrument.

Remove the on-board battery from instrument and connect it to battery charger. When the indicator lamp on the battery charger is orange, the recharging process has begun. When charging is complete (indicator lamp turns green), disconnect the charger from its power source.

Battery Removal

Before removing the battery from the instrument, make sure that the power is turned off. Otherwise, the instrument may be damaged.

The charger has built-in circuitry for protection from overcharging. However, do not leave the charger plugged into the power outlet after recharging is completed.

Be sure to recharge the battery at a temperature of $0^{\circ}\sim\pm 45^{\circ}\text{C}$, recharging may be abnormal beyond the specified temperature range .

When the indicator lamp does not light after connecting the battery and charger, either the battery or the charger may be damaged. Please connect professionals for repairing.

Rechargeable battery can be repeatedly recharged 300 to 500 times. Complete discharge of the battery may shorten its service life.

In order to get the maximum service life, be sure to recharge it at least once a month.

1.5 Reflectors

When measuring distance, a reflector prism needs to be placed at the target place. Reflector systems come with single prism and triple prisms, which can be mounted with tribrach onto a tripod or mounted onto a prism pole. Reflector systems can be self-configured by users according to the job.

1.6 Mounting and Dismounting Instrument from Tribrach

Dismounting

If necessary, the instrument (including reflector prisms with the same tribrach) can be dismantled from tribrach. Loosen the tribrach locking screw in the locking knob with a screwdriver. Turn the locking knob about 180° counter-clockwise to disengage anchor jaws, and take off the instrument from tribrach.

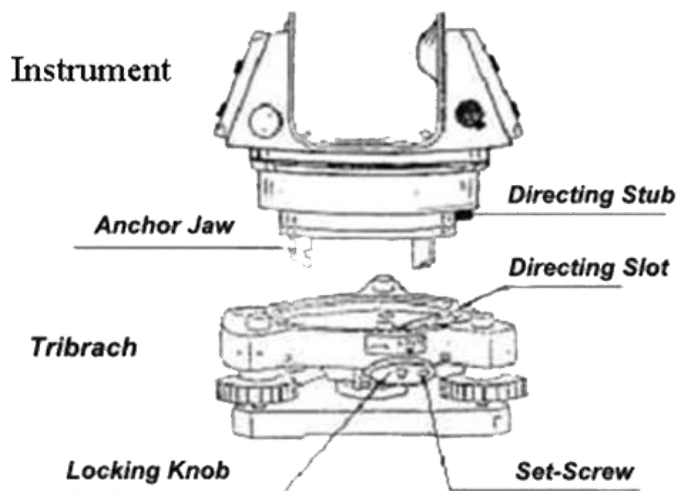

Mounting

Insert three anchor jaws into holes in tribrach and line up the directing stub with the directing slot. Turn the locking knob about 180°clockwise and tighten the locking screw with a screwdriver.

1.7 Eyepiece Adjustment and Collimating Objects

Method of Collimating Object (for reference)

- ① Sight the Telescope to bright place and rotate the eyepiece tube to make the reticle clear.
- ② Collimate the target point with top of the triangle mark in the coarse collimator. (Keep a certain distance between eye and the coarse collimator).
- ③ Make the target image clear with the telescope focusing screw.

☆If there is parallax when your eye moves up, down or left, right, it means the diopter of eyepiece lens or focus is not well adjusted and accuracy will be influenced, so you should adjust the eyepiece tube carefully to eliminate the parallax.

1.8 Powering ON/OFF

Powering on

- ① Level the instrument.
- ② Press the power bottom.

Power off

- ① Hold the power bottom for 1 second until the menu of powering off pops

up.

② Make sure the instrument is powered off normally, otherwise data may be lost.

Cautions: make sure that the battery is sufficient. If it displays "Low Battery", please change the battery or recharge it as soon as possible. Make sure the power off the instrument normally.

*During the process of data collect, do not remove the battery, otherwise the measured data will be lost.

2. OPERATION

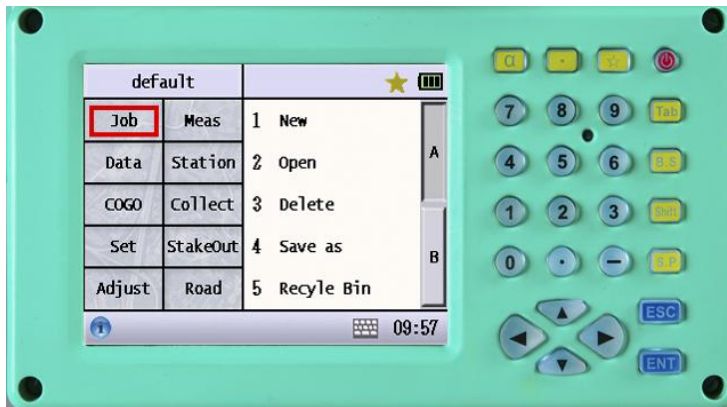

2.1 Operation Keys

| key | functions |
|--------------|---|
| α | shifting case-sensitive when inputting characters |
| ☐ | open soft keyboard |
| ★ | open the quick menu |
| ⏻ | power button |
| Tab | go to next input area |
| B.s | backspaces |
| Shift | switch between characters and numbers |
| S.P | space |
| ESC | exit |
| ENT | enter |
| ▲▼◀▶ | switch among different menus or move the cursor |
| 0-9 | input number and alphabet |
| — | input the minus or other alphabet |
| . | input decimal point |

2.2 Symbols

| character | meaning |
|------------|--|
| V | vertical angle |
| V% | vertical angle (gradient display) |
| HR | horizontal angle right |
| HL | horizontal angle left |
| HD | horizontal distance |
| VD | vertical difference |
| SD | slide distance |
| N | north coordinate |
| E | east coordinate |
| Z | elevation coordinate |
| m | meter unit |
| ft | feet unit |
| dms | "degree minute second" unit of angle measure |
| gon | "gon" unit of angle measure |
| mil | "mil" unit of angle measure |
| PSM | prism constant value |
| PPM | atmosphere correction value |
| PT | point name |

2.3 Display of Angle







The display format of angle is degree, minute, second under normal measurement mode.

e.g. : 12.2345 stands for 12° 23' 45"



When input the angle, the format is the same as above

2.4 Routine Measurement

Symbols of the routine measurement:

| symbol | function |
|---|---|
|  | Click and switch between logo and the current file name. |
|  | Display the battery level. Click to enter the setting menu of power, backlight and sound. |
|  | Quick Set key: It provides a quick way to carry out the common setting and operation. |
|  | Open or close the soft keyboard. |
| 19:42 | Displays the current time, click to enter the time and date setting. |
|  | Click to display the information of the instrument. |
|  | Do not save the modification on the current page and go back to the previous interface. |
|  | Save the modification on the current page and go back to the previous interface. |

Basic Operation

1. Press ▲▼◀▶ to switch among the different menus.
2. Press numeric key 1-5 to select sub-menu options of the corresponding menu on the main screen.
3. Press "Tab" to switch over different options.
4. User can carry out the operation by the touch pen.
5. ESC corresponds to , press and go back to the previous screen.
6. ENT corresponds to  key on some certain screens, press it and save the setting and modification on the current screen.
7. While the cursor is blinking, user should choose the textbox first, then input the detail.
8. When the touch screen is not sensitive to the stylus pen, please adjust the touch screen, and see Section 7.4.
9. When the warning, prompt or error message is popped up, please hold on a second, then the message will disappear automatically and user can move to the next operation.

3. JOB MANAGEMENT

Each job corresponds to one file. Before carrying out the measurement and other operations, user should establish a job first. The system will create a file named "default" automatically.

Measurement data and input data will be saved in the job. User can exchange the data with the job by "Import" and "Export" functions.

Job management menu:



3.1 Create New Job

- Create and open a new job, and the last job will be saved.
- The job name must be different.
- The maximum length of the job name is 8 characters, and the extension is ".job".

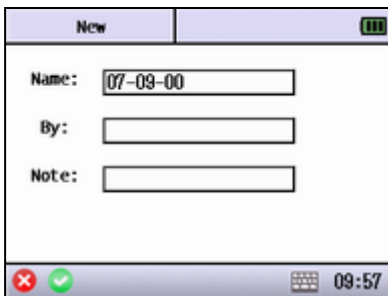

- ◆ Name: Input the job name. If not, the system will take the current date as the default name.
- ◆ By: Name of the operator.
- ◆ Note: Add note to the job.

3.2 Open Job

- Open an existing job. The previous job will be saved at the same time.
- A job should be selected before it is opened.
- Any operation will not be carried out while the current job which is showed in blue color is opened.

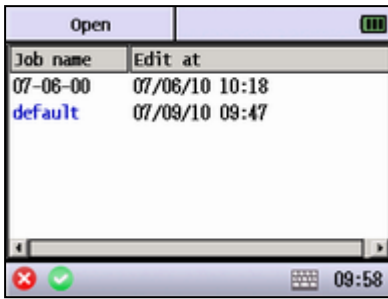

3.3 Delete Job

- Delete a chosen job which will be moved to recycle bin. User can recover the job from recycle bin.
- A job should be chosen before it is deleted.

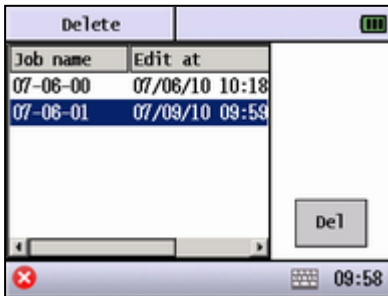

◆ [Del]: Move the chosen job to the recycle bin.

3.4 Save As

- Save the current job as a new job.

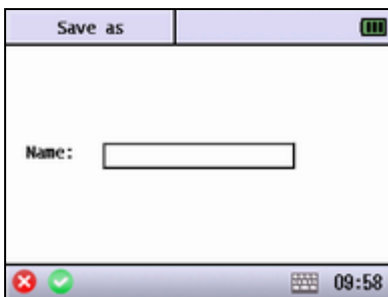

◆ Name: Input the name to be saved as.

3.5 Recycle Bin

- Operate the deleted job.

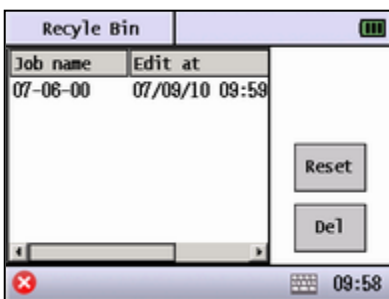

- ◆ [Reset]: Recover the chosen job
- ◆ [Del]: Delete the job permanently. The deleted job can't be recovered.

3.6 Information

- Display the current job information

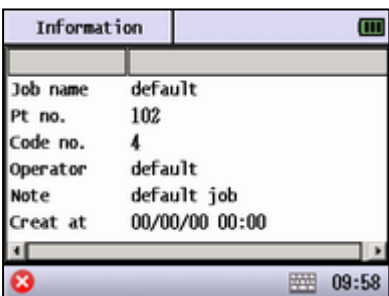

- ◆ Job name: Display the current job name.
- ◆ Pt. no. : Display the point quantity of the current job.
- ◆ Code no. : Display the code quantity of the current job.
- ◆ Operator: Display the job operator.
- ◆ Note: Note for the job.
- ◆ Create at: The creating date and time of the current job.

3.7 Import

- Import data to the current job.

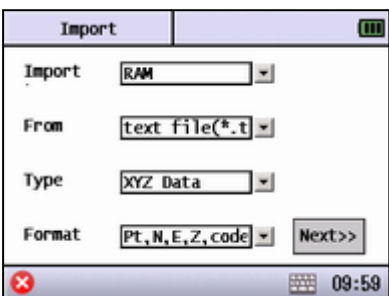

- ◆ Import: Select the storage media.
- ◆ From: Select the type of file format.
- ◆ Type: Select the type of the import file.
- ◆ Format: Select the type of data format (See appendix for more reference).
- ◆ [Next]: Move to the next step.

- Select the file to import.

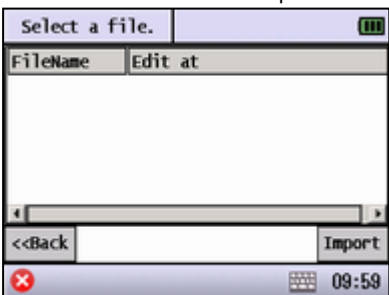

- ◆ [Back]: Back to the previous menu.
- ◆ [Import]: Select a file to import.

3.8 Export

- Export the current job.

The screenshot shows a window titled 'Export' with three dropdown menus: 'Export' set to 'RAM', 'Type' set to 'XYZ Data', and 'Format' set to 'Pt, N, E, Z, code'. A 'Next>>' button is located at the bottom right of the main area. The bottom status bar contains a red 'X' icon, a keyboard icon, and the time '09:59'.

- ◆ Export: Select the storage where to export to.
- ◆ Type: Select the type of export file.
- ◆ Format: Select the format of export file.
- ◆ [Next]: Move to the next step.

The screenshot shows a window titled 'Export' with a 'FileName' input field. Below the input field are two buttons: '<<Back' and 'Export'. The bottom status bar contains a red 'X' icon, a keyboard icon, and the time '09:59'.

- ◆ File Name: Input the name of the export file.
- ◆ Back: Back to the previous screen.
- ◆ Export: Start to export data.

3.9 About

- Display the information of the total station

The screenshot shows a window titled 'About' with the following information displayed:

| | |
|---------|------------|
| Version | 1007068004 |
| Model | RTS-880 |
| SN# | 24642 |
| HSN | 1597ecb3 |

The bottom status bar contains a red 'X' icon, 'INF' and 'OTHE' labels, a keyboard icon, and the time '09:59'.

- ◆ Version: The firmware version.
- ◆ Model: The model name.
- ◆ SN#: The serial number of total station.

4. DATA MANAGEMENT

In this function, user can view, add, delete and edit the data of the current file.

Data Management Menu:

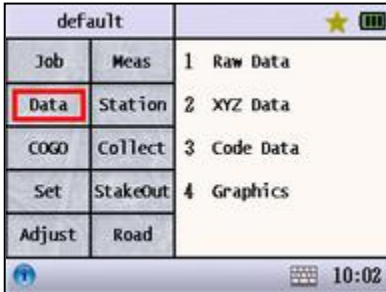

4.1 Raw Data

- Display the raw data list. (See appendix for more reference)

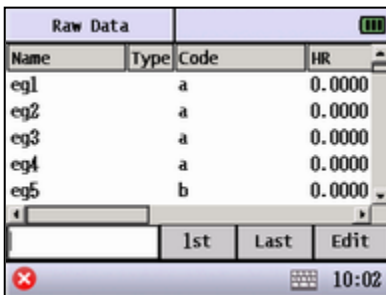

◆ Input the point name in the edit box, and the system will go to the first data which is completely matched.

◆ [1st]: Go to the first data.

◆ [Last]: Go to the last data.

◆ [Edit]: Edit the selected raw data. Only point name and code can be edited.

- User can edit the point name and code of the selected raw data, The measurement data of the raw data cannot be modified.

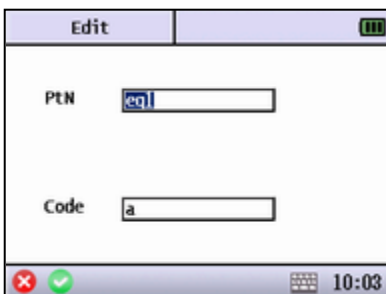

◆ PtN: Input the new name of raw data.

◆ Code: Input the new code of raw data.

4.2 XYZ Data

- Display the coordinates data list.
- Three types of the coordinates data: input, measured and calculated.

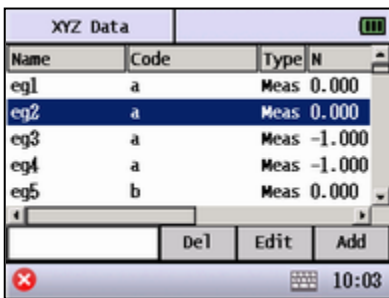

◆ Input the point name in the edit box, and the system will go to the first data which is completely matched.

- ◆ [Del]: Delete the selected data.
- ◆ [Edit]: Edit the selected data.
- ◆ [Add]: Input a coordinates manually.

- Screen of editing the current coordinates data.
- If the coordinates data is measurement data, the N, E, Z cannot be edited.

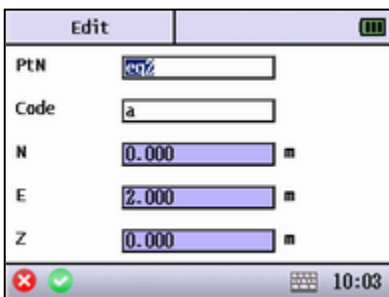

◆ PtN: Input the new name of coordinate data

◆ Code: Input the new code of coordinates data

- ◆ N: Input the new North coordinate.
- ◆ E: Input the new East coordinate.
- ◆ Z: Input the new elevation coordinate.

- screen of adding new coordinate



◆ PtN: Input the name of new point

◆ Code: Input the code of new point

◆ N: Input the North coordinate of new point

◆ E: Input the East coordinate of new point

◆ Z: Input the Elevation coordinate of new point

4.3 Code Data

- Display code data list

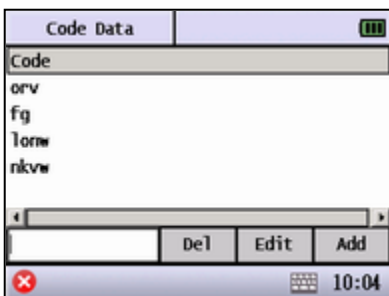

◆ Input the code in the edit box, and the system will go to the corresponding code.

- ◆ [Del]: Delete the selected code
- ◆ [Edit]: Edit the selected code
- ◆ [Add]: Add a new code

4.4 Graphics

- Display the graphics of current coordinate data.

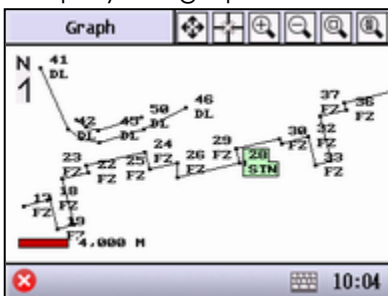

: Display all point.



: Station and backsight point. If there is no station, the system will display all points.



: Zoom in.



: Zoom out.



: Partly enlarge.



: Set up the display or find a fixed point.

- Searching graphics and setting display.

◆ PtN: Input the point name.

◆ [Find]: Go back to the graphics screen and highlight the point to find.

◆ [Pt]: Whether to display the point name

◆ [PtN]: Whether to display the point name of coordinate data.

◆ [Code]: Whether to display the code of coordinate data.

◆ [Link]: Whether to display the line information of coordinate data.

◆ [OK]: Set up the modification and go back to the graphics screen.

5. COGO

COGO can complement the routine calculation and surveying calculation, and save the results.

Display of COGO

| default | | | |
|---------|----------|---|--------------|
| Job | Meas | 1 | Calculator |
| Data | Station | 2 | Cal.XYZ |
| COGO | Collect | 3 | Inverse |
| Set | StakeOut | 4 | Area&Perim |
| Adjust | Road | 5 | Pt-L Inverse |

| default | | | |
|---------|----------|---|---------------|
| Job | Meas | 1 | 2 Pt Intersec |
| Data | Station | 2 | 4 Pt Intersec |
| COGO | Collect | 3 | Volume |
| Set | StakeOut | 4 | Unit |
| Adjust | Road | | |

5.1 Calculator

•Scientific Calculator (Only introduce the special function keys. The other functions are the same as ordinary symbols of common calculator)

- ◆ [Clr]: Clear.
- ◆ [Past]: Paste the data from the clipboard to the edit box.
- ◆ [Cop]: Copy the current calculated result to the clipboard.
- ◆ [DEL]: Delete the recent input characters.
- ◆ [C]: Clear the edit box and finish the calculation without clearing the screen.
- ◆ [Pi]: Input the approximation of π to the edit box.

5.2 Calculate XYZ

•To calculate the coordinates of one point in accordance with a known point, angle and the distance.

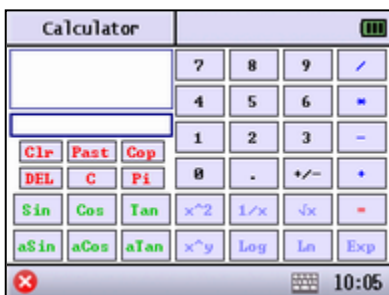

- ◆ StrtPt: Start point. Input a known point
- ◆ : Call up a known point.
- ◆ StrtAg: Start angle. A known angle starts from the start point.
 - ◆ +Ang: The right angle value rotated from the start point.
 - ◆ HD: Horizontal distance from start point to calculated point
 - ◆ VD: Vertical difference between start

point and the point to calculate.

◆ [Save]: Save the calculation result after an effective calculation.

◆ [Cal.]: Calculate the coordinates according to the known data. The result will be displayed in the “calculation result area”.

5.3 Inverse

● Calculate angle and distance between two known point

◆ StrtPt: Start point. Input a start point.

◆ End Pt: End point. Input an end point.

◆ : Call up or input a known point.

◆ HD: Horizontal distance between two points.

◆ SD: Slide distance between two points

◆ VD: Vertical difference between two points.

◆ V%: Slope of two points.

◆ Angl: Angle between two points.

◆ [Cal.]: Begin to calculate.

5.4 Area & Perimeter

● Calculate the area of known points

| PTN | N | E |
|------|----------|-----------|
| 99 | 0.000 | 0.000 |
| ebb | 2855.000 | 4791.000 |
| bbc | 3368.000 | 9593.000 |
| fmjj | 1397.000 | 15381.000 |

◆ The added data will be displayed on the list

◆ [ADD] or [Insert]: Choose the place of the added point.

◆ : Add a point data to the list

◆ [Del]: Delete a chosen data on the list

◆ [Cal.]: Calculate the area of current known point data.

◆ {Res1}: Display the last calculation result.

- Screen of last calculation result

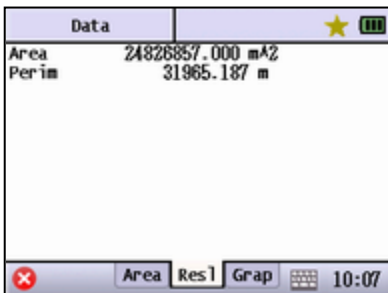

- Display graphics of the area, the area zone will be shown in black.

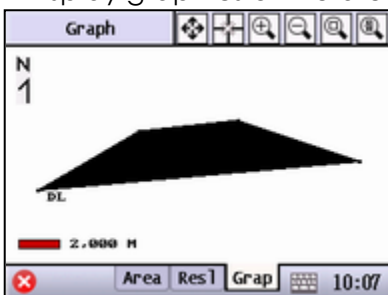

5.5 Pt-Line Inverse

● According to the line from the start point to end point, make a straight line perpendicular to the offset point. The calculation results are the horizontal distance between start point and pedal, and the horizontal distance between offset point and pedal.

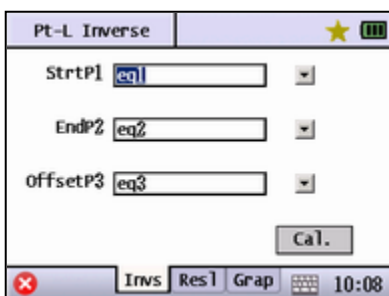

- ◆ StrtP1: Input or recall the coordinate of start point.
- ◆ EndP2: Input or recall the coordinate of end point.
- ◆ OffsetP3: Input or recall the coordinate of offset point.
- ◆ [Cal.]: Start to calculate after inputting three known points.

- Display the Pt-Line Inverse result.

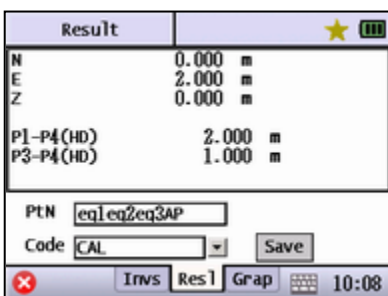

- ◆ [Save]: Save the coordinates of the pedal.

- Display the Pt-Line Inverse graphics.

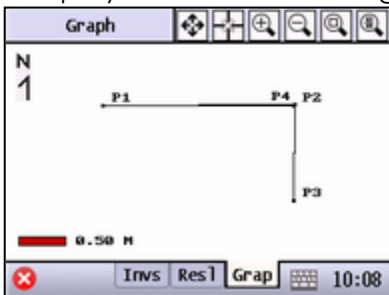

5.6 2 Points Inverse

According to two start points, and the angle or distance between these two points and intersection point, the coordinates of the intersection point can be computed.

- Calculate the intersection point by two distance values.

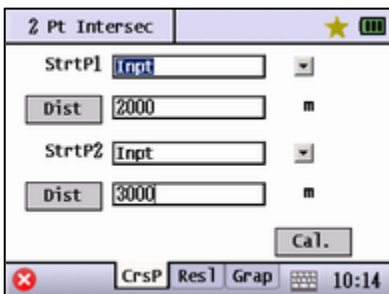

- ◆ [Dist]: Switch between angle and distance.

- ◆ [Cal.]: Calculate the coordinates of intersection point.

- Calculate the coordinate of intersection point by the azimuth.

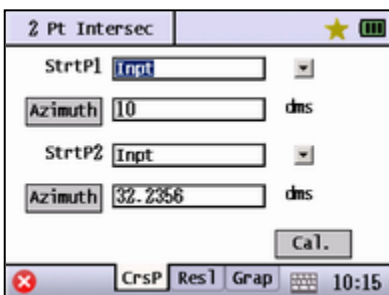

- ◆ [Azimuth]: The angle from start point to intersection point.

- Calculate the intersection point by distance and angle.

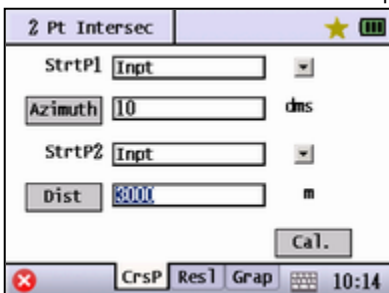

- The result will be displayed in the following screen according to the number of the intersection points.

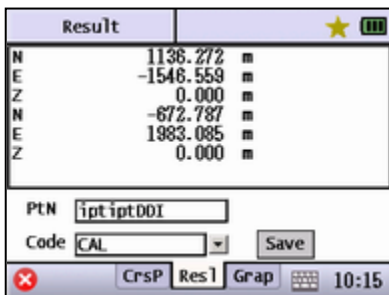

- ◆ [Save]: Save the coordinates of intersection point. The name of the next intersection point will be accumulated automatically.

- Graphics of intersection calculation (The shown figure bases on the distance calculation.)

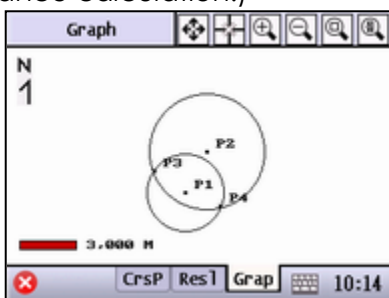

5.7 4 Points Inverse

- Calculate intersection point of two lines which are formed by four points

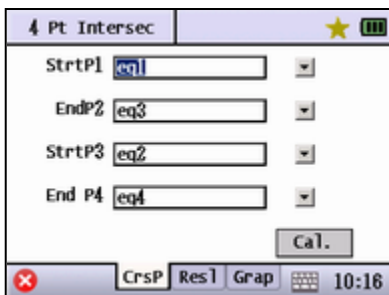

- ◆ StrtP1: The start point of straight line
- ◆ EndP2: The end point of straight line
- ◆ [Cal.]: Calculate the coordinate of the intersection point.

- Display the result of calculation.

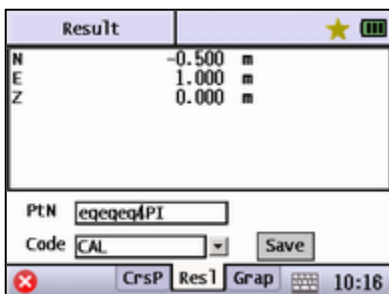

- ◆ [Save]: Save the result and the point.

- Graphics of 4 Points inverse.

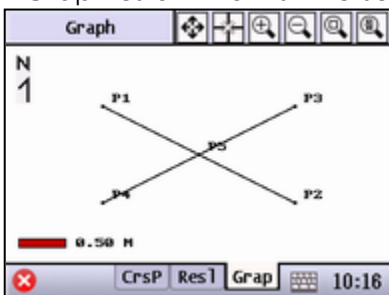

5.8 Volume

- The system will create a triangulation network with the points in the list, and take the reference height as the reference plane to calculate the volume.

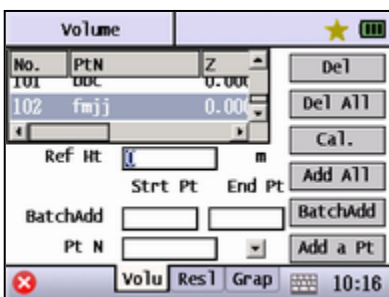

◆ Ref HT: Input the reference height which is used to calculate, the plus volume is above the reference height, and the minus one is beneath the height.

◆ [Del]: Delete the selected point in the list.

◆ [Del All]: Delete all points in the list.

◆ [Cal.]: Calculate the volume according to the reference height and points in the list.

◆ [Add All]: Add all the points of the current job to the list. The maximum is 200.

◆ [Batch Add]: Add a batch of calculating points.

◆ [Add a Pt]: Add a point to the list.

- Result of volume calculation.



◆ +V: Volume which is above the reference height.

◆ -V: Volume which is beneath the reference height.

◆ Total: Sum of +V and -V.

- Graphics of volume calculation.

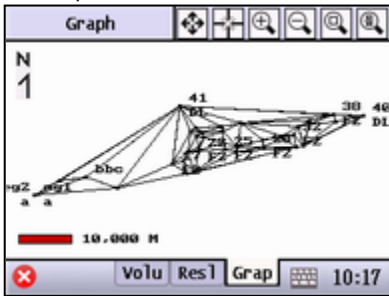

5.9 Unit

- Convert the value according to the selected unit. After inputting the value, the system will automatically calculate the result of conversion.

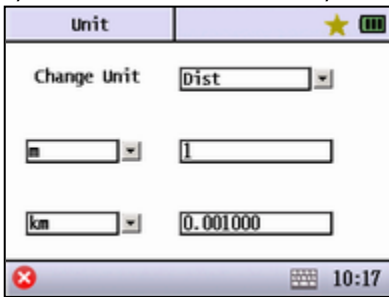

6. SET

“Set” can be classified into two types: one refers to job setting, which will affect the current job; the other is not related to the current job. Instead, it affects all the jobs.

- The following settings belong to the first type.
- The [Default] key can save the current setting as default. When setting the next job, the system will use the setting of the first type as parameter of the new job.

The Menu of “Set”

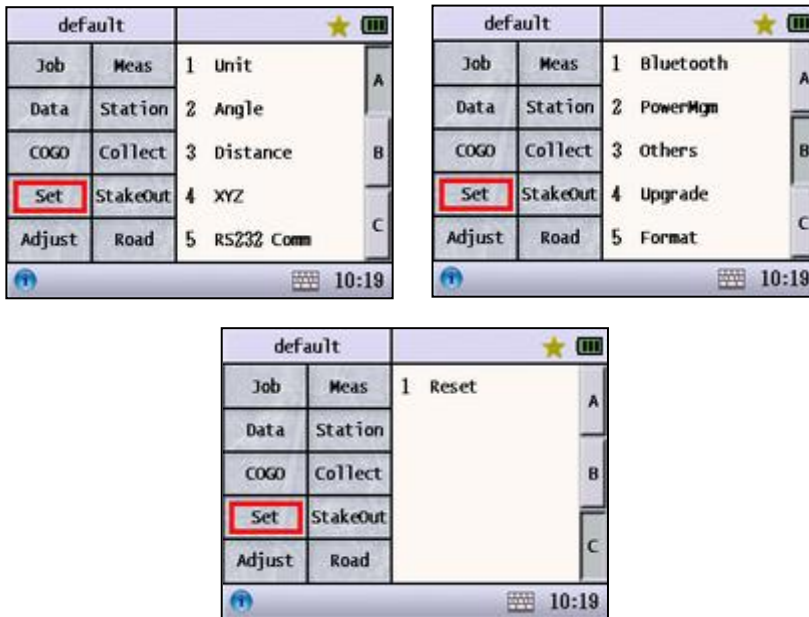

6.1 Unit Setting

- Set the unit.

The unit is relevant to a certain job. Different job may employ different unit.

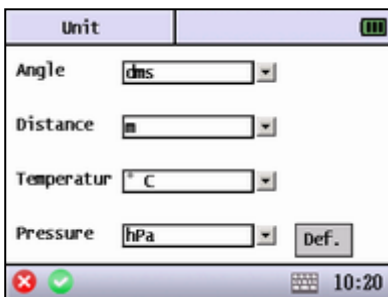

◆Angle: Set the angle unit of the current job.

◆Distance: Set the distance unit of the current job.

◆Temperature: Set the temperature unit of the current job.

◆Pressure: Set the pressure unit of the current job.

◆[Def.]: Set the current setting as default. While creating a new job, the system will

adopt the current setting.

6.2 Angle Setting

- Set the angle.

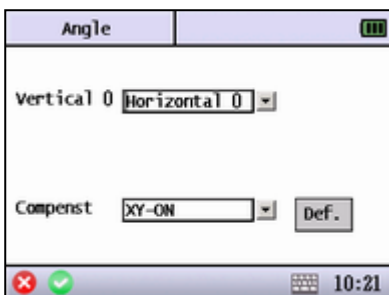

- ◆ Vertical 0: Set the vertical angle display of the current job as Horizontal 0 or Zenith 0.

- ◆ Compenst: Set ON/OFF of the compensator.

- ◆ [Def.]: Set the current setting as default. While creating a new job, the system will adopt the current setting.

6.3 Distance Setting

- Set the distance.

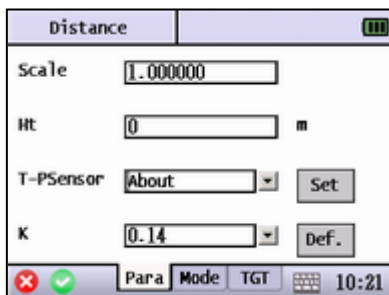

- ◆ Scale: Set the scale factor of measurement station of the current job.

- ◆ Ht: Set the height of the station of the current job.

- ◆ T-P Sensor: Set ON/OFF of the temperature and pressure sensor.

- ◆ K: Set the correction parameter of atmosphere refraction modulus and earth curvature radius.

- ◆ [Set]: Set the correction parameter of temperature and pressure.

- ◆ [Def.]: Set the current setting as default. While creating a new job, the system will adopt the current setting.

- Set the distance measure mode

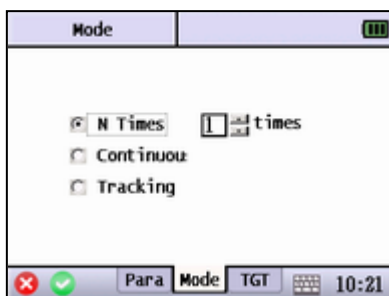

- ◆ N Times: Set the measuring times, 1-5 optional.

- ◆ Continuous: Set the continuous fine measurement.

- ◆ Tracking: Set the tracking measurement, with fast speed but lower accuracy.

- Set the measuring target.
- If the EDM is infrared type, "Sheet" and "Non-Prism" cannot be chosen.

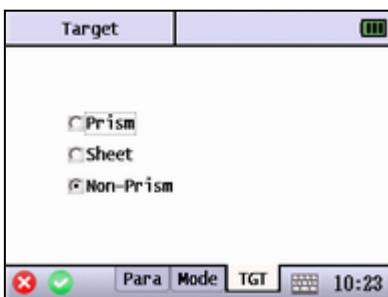

- ◆ [Prism]: Set the measuring target to prism.
- ◆ Const: Set the prism constant.
- ◆ [Sheet]: Set the measuring target to reflecting sheet.
- ◆ [Non-Prism]: Set the measuring target to other material.

6.4 NEZ Setting

- Set the parameter of coordinate.

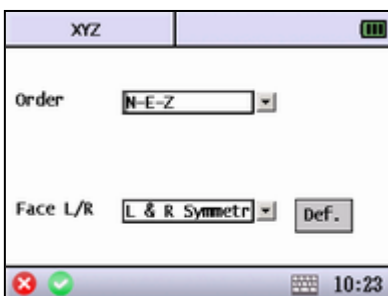

- ◆ Order: Set the display order of coordinate.
- ◆ Face L/R: Set whether the coordinate value is relative to instrument's left face or right face, if not, the measurement results on both left face and right face are the same.
- ◆ [Def.]: Set the current setting as default. While creating a new job, the system will adopt the current setting.

6.5 RS232 Communication Setting

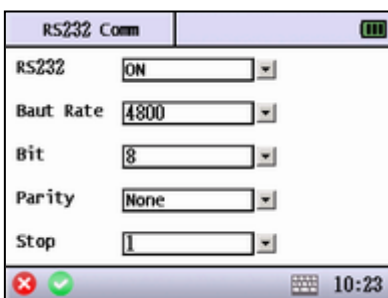

- Set the parameter of RS232 communication
- ◆ RS232: Whether to open the RS232 data port. When the Bluetooth is on, the RS232 port will be shut down automatically.
- ◆ Baud Rate: Set the baud rate of communication port.
- ◆ Bit: Set the data bit of communication port.
- ◆ Parity: Set the parity bit of communication port.
- ◆ Stop: Set the stop bit of communication port.

6.6 Bluetooth

- Set the parameter of Bluetooth.

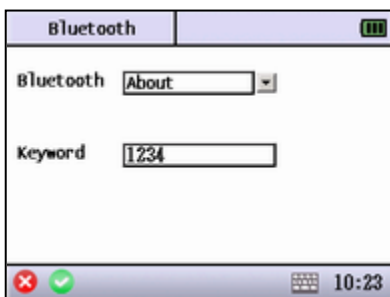

- ◆Bluetooth: Set ON/OFF of the Bluetooth. When the RS232 is on, the Bluetooth will shut down automatically.

- ◆Keyword: Input the keyword.

6.7 Power Management

- Power Management Setting.

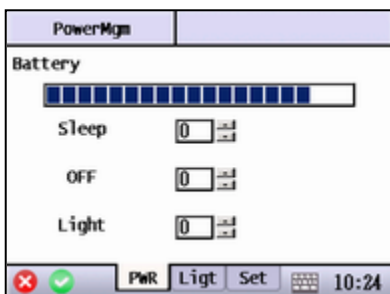

- ◆Battery: Display the remaining power.
- ◆Sleep: Set the sleep time while the instrument is not being operated.

- ◆OFF: Set the power off time while the instrument is not being operated.

- ◆Light: Set the light off time while the instrument is not being operated.

- Light setting

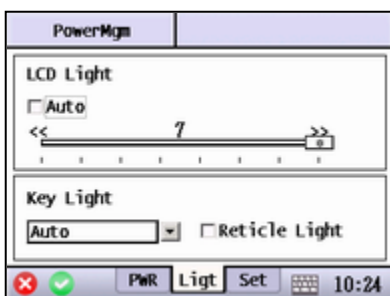

- ◆Auto: The instrument will automatically set the intensity of LCD light according to surroundings.

- ◆Key Light: Set ON/OFF of the keyboard backlight.

- ◆Reticule Light: Set ON/OFF of the reticle light.

- Other Settings of the Power Management

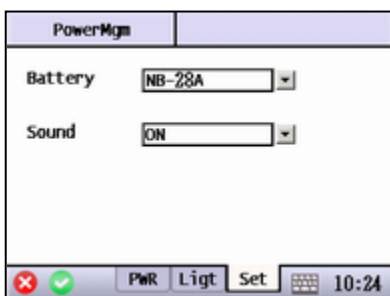

- ◆ Battery: Choose the battery type according to the battery in use.

- ◆Sound: Set ON/OFF of sound.

6.8 Other

- Other settings.



◆ Language: Choose the display language

6.9 Upgrade

- Upgrade the programs of the total station firm wares.
- First, contact your local dealer and request for an upgrading program package. Copy the package to the RAM, SD card or U-disk. Then press the corresponding key to start upgrading. Before upgrading, the current version will be shown, user cannot upgrade when the hardware version is inconsistent.
- The upgrade software cannot be renamed. Only one upgrade software can be stored in a storage media.

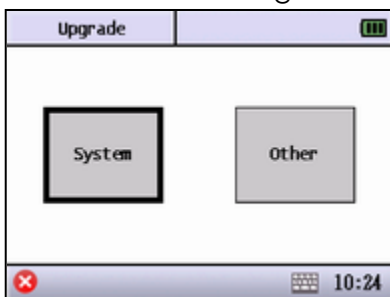

- ◆System: Upgrade the system firmware.
- ◆Other: Upgrade other firmwares.

- Types of other firmware upgrade

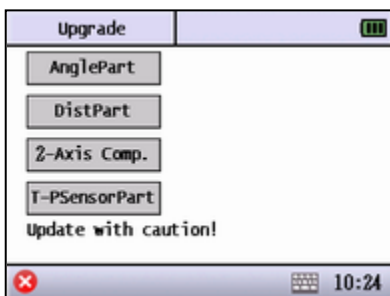

- ◆ [AnglePart]: Upgrade the angle firmware
- ◆ [DisPart]: Upgrade the distance firmware
- ◆ [2-Axis Comp.]: Upgrade 2-axis compensator firmware
- ◆ [T-PSensorPart]: Upgrade the temperature and pressure sensor firmware

●System upgrade Screen

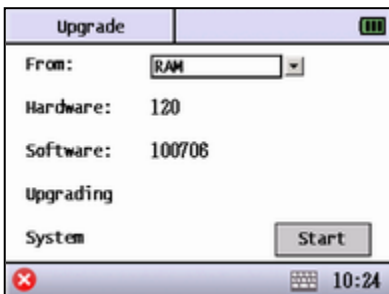

- ◆From: Choose the storage media where the upgrade software is stored.
- ◆ Hardware: The corresponding hardware version.
- ◆Software: Display the current software version.
- ◆ Upgrading: Display the upgrade software version.
- ◆System: Display the upgrade software in used is for the system hardware upgrade.
- ◆[Start]: Start to upgrade.

6.10 Format

●Format the current memory.

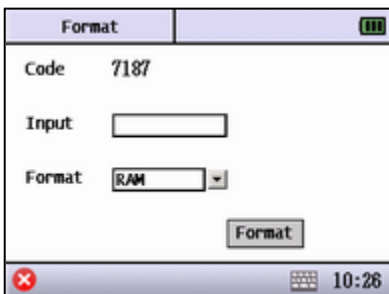

- ◆ Code: The system will create an identification code randomly.
- ◆Input: Input the code above.
- ◆Format: Choose the memory to format.
- ◆[Format]: Start to format.

6.11 Reset

●Reset to default settings.

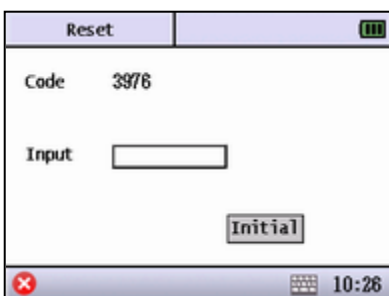

- ◆ Code: The system will create an identification code randomly.
- ◆Input: Input the code above.
- ◆[Initial]: Start to reset.

7. ADJUSTMENT

Menu of Adjustment

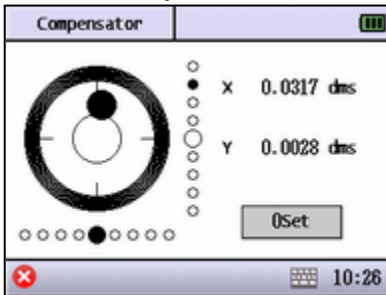

7.1 Compensator

- Adjustment of the dual-axis compensator.
- First, adjust and level the plate vial. Then, press the “0Set” key to set the value of X and Y to 0.

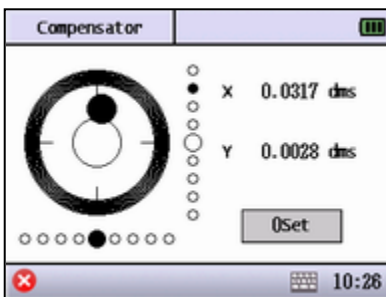

◆ [0Set]: Set the compensator as 0 in the current state, after that, the instrument will set the current state as leveling state.

7.2 V0 Adjustment

The adjustment of vertical index difference (the so-called i-angle). This item must be adjusted after finishing the compensator adjustment and crosshair adjustment.

Inspection

1. After leveling the instrument, collimate at any target A and read the angle value of Face L. Record the value as L.
2. Rotate the telescope and collimate at the target A with Face Right, read and record the angle value as R.
3. If the vertical angle is 0° in zenith, $i = (L + R - 360°) / 2$.
4. If the vertical angle is 0° in horizon, $i = (L + R - 180°) / 2$ or $i = (L + R - 540°) / 2$.
5. 4 If $|i| \geq 10''$ shall set the Vertical Angle 0 Datum again.

Adjustment:

1. Precisely sight any target A in same height with the instrument in Face Left, and read the vertical angle value L.

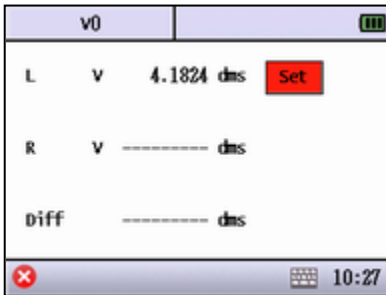

◆ [Set]: Set the angle value on Face Left.

2. Precisely sight at the same target A on Face Right.

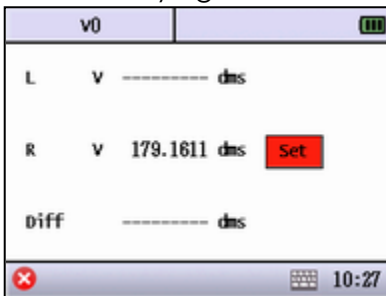

◆ [Set]: Set the angle value on Face Right.

3. After setting the angle in both Face Left and Right, the screen will display the index difference, press [√] to set the adjustment.

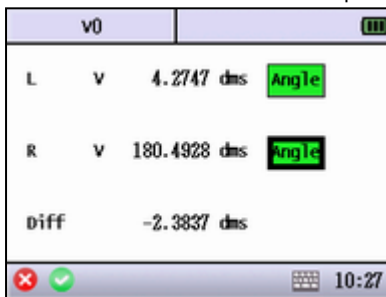

4. Repeat the inspection steps to check the Index Difference (i angle). If the Index Difference cannot meet the requirement, you should check whether the three steps of the adjustment are right. Then set again according to the requirement.
5. If the Index Difference still fails to meet the requirement after repeated operation, the instrument should be returned to authorized service center for inspection and repair.

● The value of vertical angle is not adjusted and compensated in the OSet process. It is just for reference.

7.3 Additive Constant

The Instrument constant has been checked and adjusted in the factory, and $K=0$. It seldom changes and it is suggested to check once or twice every year. The inspection should be made on the base alignment, also can be made according to the following method.

Inspection

1. Mount and level the instrument on Point A on flat ground. Use the vertical hair to mark Point B and Point C with the distance of 50m on the same line, and collimate the reflector accurately.
2. After setting temperature and pressure value, measure the horizontal distance of AB and AC accurately.
3. Set the instrument on Point B and center it accurately. Measure the horizontal distance of BC accurately.
4. Then you can get the Instrument Constant:

$$K = AC - (AB + BC)$$

The value of K should be close to 0. If $|K| > 5\text{mm}$, the instrument should be strictly inspected on the base alignment, and be adjusted according to the inspection value.

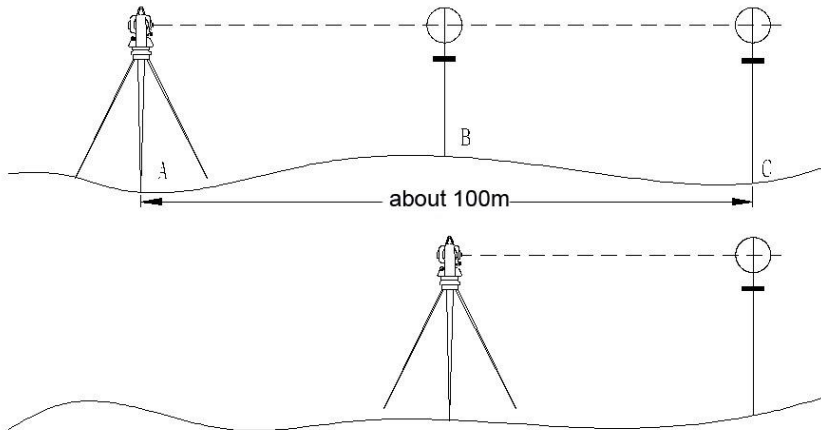

Adjustment

If the inspection suggests that the Instrument Constant K has changed (not close to 0), set the Stadia Constant in accordance with the Constant K.

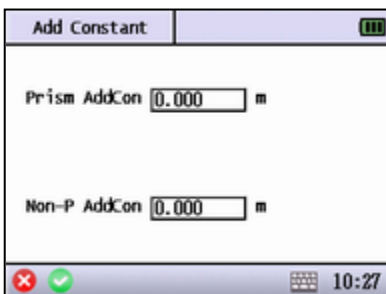

◆ Prism AddCon: The additive constant K of the prism mode.

◆ Non-P AddCon: The additive constant K of non-prism mode.

- Set the orientation through the vertical hair to make Point A,B, and C on the same line strictly. There must be a fixed and clear centering mark under the Point B.

- The coincidence of the center of the prism and the center of the instrument is very essential to the measuring accuracy. Therefore, it's best to use a tripod or a common-used tribrach on the piont B. If we replace it with a three-foot adaptor and a tribrach, make sure that they are stable and fixed. It is possible to reduce the inconsistency if we just replace the upper part of the prism and the upper part of the instrument.

7.4 LCD Adjust

- Due to different affecting factors, the position of LCD may have offset. In this case, the LCD Adjustment may require.

- Precisely click at the center of the cross with the indication. After finishing the adjustment, the screen will go back to “Adjust” menu while the adjustment is successful. If not, the user should repeat the adjustment.

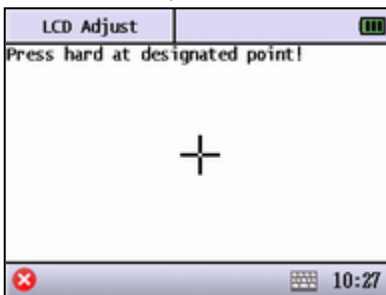

8. MEASUREMENT

In Measure mode, user can carry out some basic survey operation.

Menu of Measurement



8.1 Angle

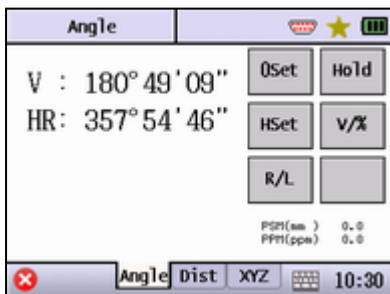

- ◆ V: Display the vertical angle.
- ◆ HR or HL: Display horizontal angle on Face Left or Face Right.
- ◆ [0Set]: Set the current horizontal angle to 0°. After that the backsight point should be set again.
- ◆ [Hold]: Hold the horizontal angle until releasing it.
- ◆ [HSet]: Set the horizontal angle by inputting a certain value, after that the backsight should be set again.

●Screen of HSet

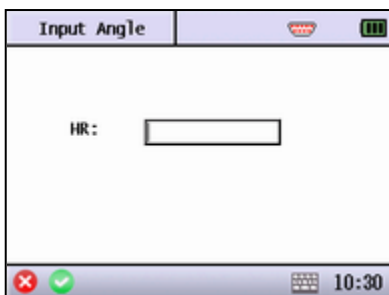

- ◆ HR: Input the horizontal angle
- ◆ [V/%]: Switch the display of angle between regular vertical angle and slope percentage.
- ◆ [R/L]: Switch between Face Left or Right.

8.2 Distance

- Screen of distance measurement.

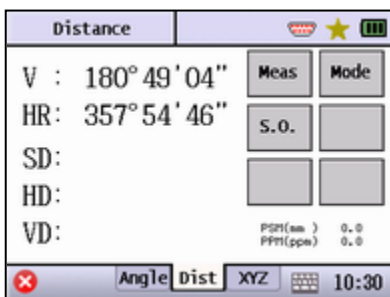

- ◆ SD: The slide distance.
- ◆ HD: The horizontal distance.
- ◆ VD: The vertical distance.
- ◆ [Meas]: Start to measure.
- ◆ [Mode]: Enter the measure mode setting, see Mode Setting for more detail.
- ◆ [S.O.]: Enter to the stake out mode.

- Screen of S.O.

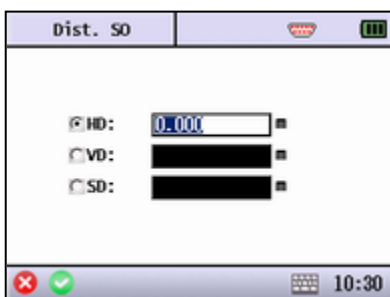

- ◆ [HD]: Input the horizontal distance of stake out point.
- ◆ [VD]: Input the vertical distance of stake out point.
- ◆ [SD]: Input the slide distance of stake out point.

8.3 Coordinates

- Screen of coordinates measurement.

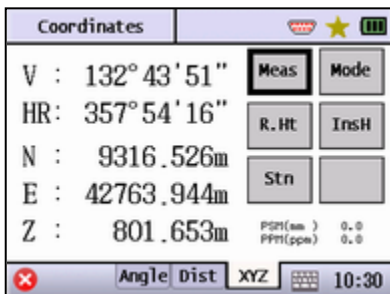

- ◆ N: North coordinate.
- ◆ E: East coordinate.
- ◆ Z: Elevation coordinate.
- ◆ [Meas]: Start to measure.
- ◆ [Mode]: Set the surveying mode.
- ◆ [R.Ht]: Input the reflector height.

- Screen of inputting reflector height.

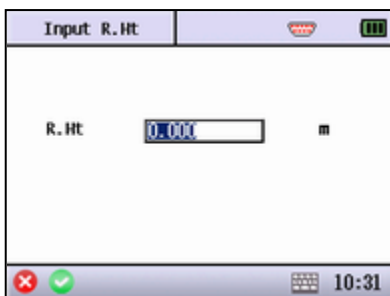

- ◆ R.Ht: Input the reflector height.

- [InsH]: Input the instrument height, after that the backsight should be set again.

- Screen of inputting instrument height.

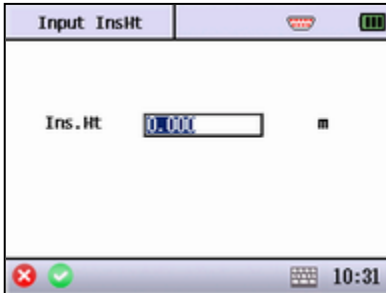

- ◆Ins.Ht: Input the instrument height
- ◆[Stn]: Input the coordinates of station, after that the backsight should be set again.

- Screen of inputting coordinate of station.

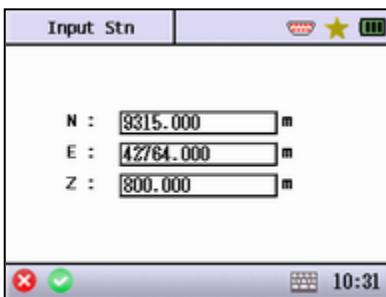

- ◆N: Input North coordinate.
- ◆E: Input East coordinate.
- ◆Z: Input Elevation coordinate.

9. STATION

Before surveying and staking out, user should set the station by known points.

Menu of Station setting

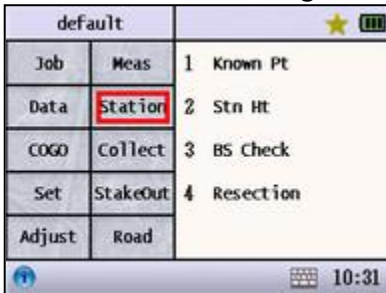

9.1 KnownPt

●Set the backsight point by the known point. There're two ways to set the backsight point: one is by the coordinates of the known point, the other is by the angle of the known point.

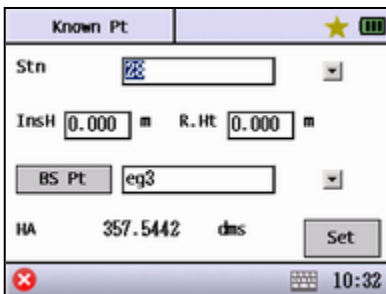

◆Stn: Input the name of known point, call up or create an known station point by dragging down ▾.

◆InsH: Input the instrument height.

◆R.Ht: Input the reflector height.

◆BS Pt: Input the name of the known backsight point, recall or create a known backsight point by dragging down ▾.

◆HA: Display the current horizontal angle.

◆Set: Set the angle of backsight point according to the current input. If the input data do not meet the calculating demand, the system will display a warning.

- Inputting the angle of backsight point to set the station.

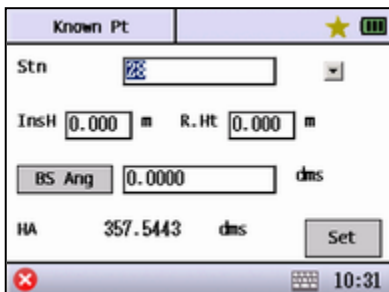

- ◆ BS Ang: Input the angle value of backsight point.

9.2 Stn Ht

- Calculate the station height by measuring a point with known height.
- User should set the station before setting the station height.

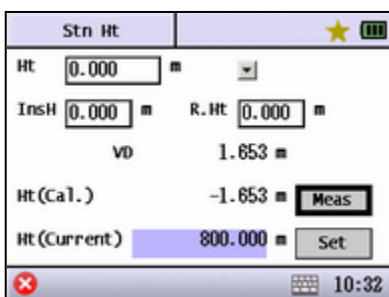

- ◆ Ht: Input the height of known point, user can recall the height of known point by dragging down .

◆ R.Ht: The height of current prism in use.

◆ InsH: The height of current instrument.

◆ VD: Display the current vertical angle.

◆ Ht (Cal.): Display the result of calculated station height.

◆ Ht (Current): Display the current station height.

◆ [Meas]: Start to measure and calculate the station height automatically.

◆ [Set]: Set the calculation result as the station height.

9.3 BS Check

- Check whether the current angle is in accord with the backsight angle.
- User should set the station before checking the station height.

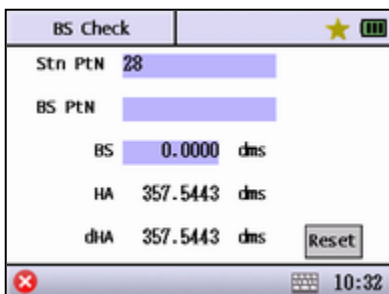

◆ StnPtN: The station point name.

◆ BS PtN: The backsight point name. This will be blank if the backsight angle is input by manually.

◆ BS: Display the backsight angle.

◆ HA: Display the current horizontal angle.

◆ dHA: Display the difference between backsight angle and horizontal angle.

◆ [Reset]: Reset the current horizontal angle as the backsight angle.

9.4 Resection

● If the angle between the first measurement point and the second one is too small or too large, it will influence the geometrical accuracy of calculation result. In this reason, selecting a geometrical graphic with good structure is important.

● Resection calculation requires at least three angle measurements or two distance measurements.

● Basically, the station height is calculated by the distance measurement data. If the distance measurement was not carried out, the height is determined by the angle measurement of known point.

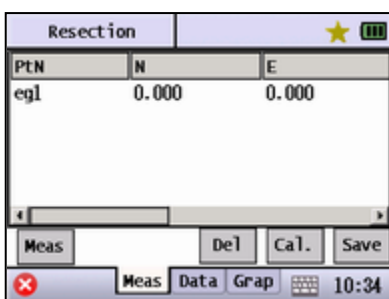

◆ List: The list of measured known points.
 ◆ [Meas]: Enter the screen of known point measurement.

◆ [Del]: Delete a selected measured known point.

◆ [Cal.]: Calculate the measured points on the list.

◆ [Save]: Save the calculation result for the use of setting station.

◆ {Data}: Display the calculation result.

◆ {Grap}: Display the measurement result in graphics.

● Screen of known point measurement.

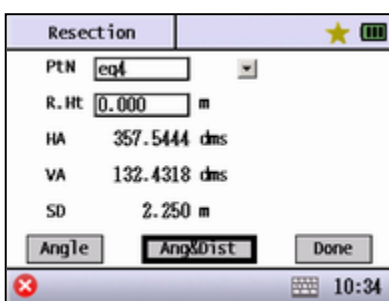

◆ PtN: Input a known point name.

◆ R.Ht: Input the reflector height.

◆ HA: Display the measured horizontal angle result.

◆ VA: Display the measured vertical angle result.

◆ SD: Display the measured slide distance result.

◆ [Angle]: Only launch the angle measurement.

◆ [Ang&Dist]: Launch the distance and angle measurement.

◆ [Done]: Measurement completes. Save the measurement result and go back to the previous screen.

10. COLLECT

After setting the station, user can start to collect data.

Menu of data collect

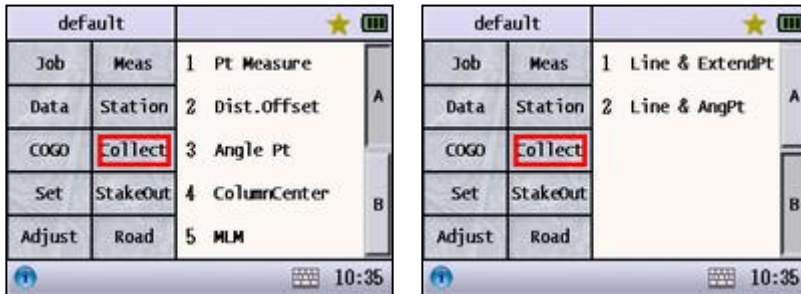

10.1 Pt Measure

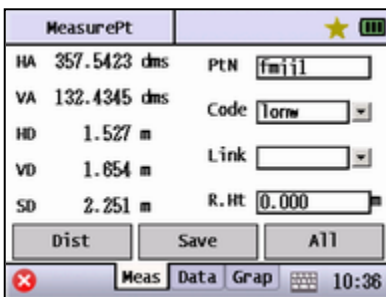

- ◆ HA: Display the current horizontal angle.
- ◆ VA: Display the current vertical angle.
- ◆ HD: Display the measured horizontal distance.
- ◆ VD: Display the measured vertical distance.
- ◆ SD: Display the measured slide distance.

◆ PtN: Input the name of the point to be measured. The system will plus "1" automatically to the point name after each saved measurement.

◆ Code: Input or call up the code of measuring point.

◆ Link: Input the known point name, the system will create a line from the known point to current point, and this line will display in graphics. Every time when the code changes, some points with the same code will be displayed automatically.

◆ R.Ht: Display the current prism height.

◆ [Dist]: Start distance measurement.

◆ [Save]: Save the previous measurement result. If the distance measurement was not carried out, the system will save the current angle value only.

◆ [All]: Measure and save.

◆ {Data}: Display the previous measurement result.

◆ {Grap}: Display the current coordinates graphics.

10.2 Dist.Offset

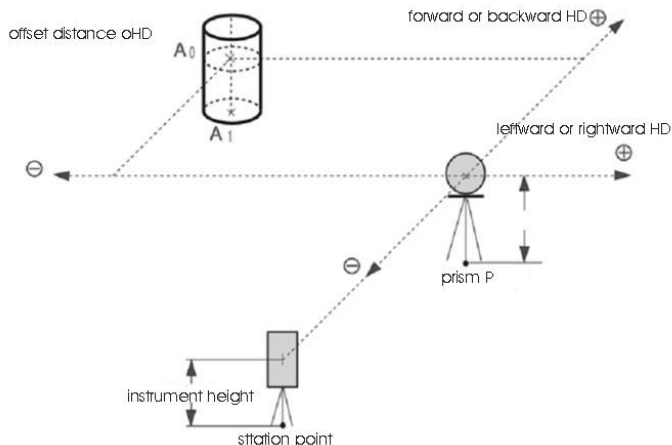

- All directions are correspondent to the visual angle of surveyor.

| Dist.Offset | |
|----------------------|---------------|
| PTN | fm11 |
| Code | R. Ht 0.000 m |
| ← → | 0.000 m |
| Fore Back | 0.000 m Meas |
| ↑ ↓ | 0.000 m All |
| Meas Data Grap 10:36 | |

◆ PtN: Input the name of the point to be measured.

◆ Code: Input or call up the code.

◆ R.Ht: Input the current prism height.

◆ [←][→]: Input the left or right offset HD.

◆ [Fore] [Back]: Input forward or backward offset HD.

◆ [↑][↓]: Input upward or downward offset HD.

◆ [Meas]: Start to measure.

◆ [All]: Measure and save.

◆ {Data}: Display the calculated coordinates and measurement result.

◆ {Grap}: Display the graphics of distance offset HD.

10.3 Angle Pt

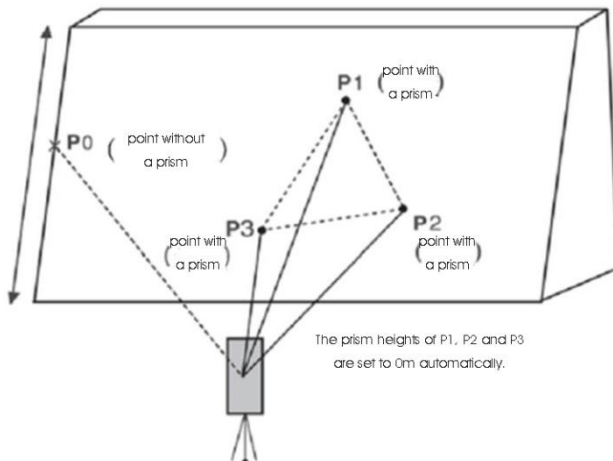

•As shown in the above figure, the prism points are the measurable points while the total station is in the non-prism measure mode, and the point without a prism is arbitrary.

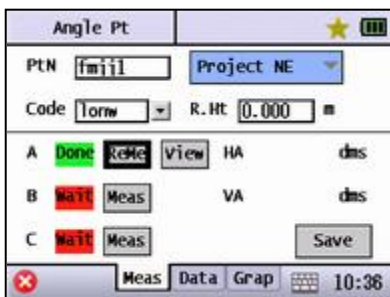
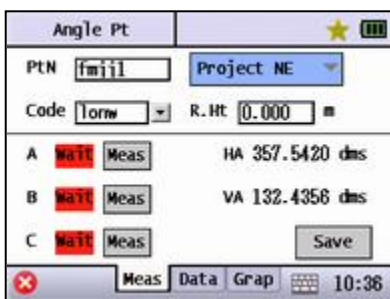

- ◆ PtN: The name of the point to be measured.
- ◆ Code: Input or call up a code.
- ◆ R.Ht: The current prism height.
- ◆ Done: The current point has been measured.
- ◆ [ReMe]: Re-measure the current point.
- ◆ [View]: View the result of the current measuring point.
- ◆ Wait: The next point to be measured.
- ◆ [Meas]: Measure the current point.
- ◆ [Save]: Save the current calculation result.
- ◆ HA: The current horizontal angle.
- ◆ VA: The current vertical angle.
- ◆ [Projection NE]: User can choose the projection ways in {Grap} according to the specific circumstances.
- ◆ {Data}: After measuring three effective points, the screen will display the intersection coordinate.
- ◆ {Grap}: Display the intersection point and other three points.

10.4 Column Center

- First, measure the column point P1 directly, then, after measure the angle of column point P2 and P3, the system can calculate the coordinates, distance and angle of the column center.
- The angle of center point is average value of P2 and P3.

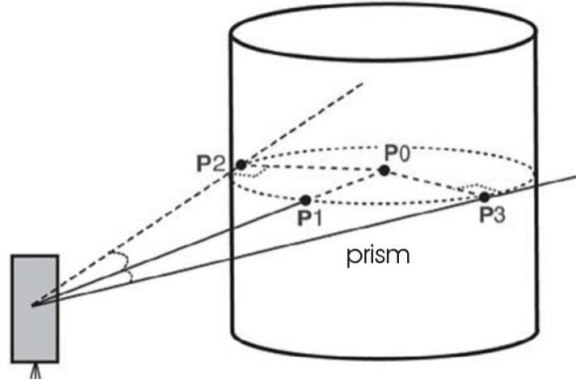

| ColumnCenter | |
|---|-----------------------------------|
| PTN | fwi1 |
| Code | Fq R.Ht: 0.000 m |
| DrctA | Angle HA 357.5425 dms |
| DrctB | Angle HA 348.2203 dms |
| Centr | ReMe HD 1.530 m Save |
| Meas Data Grap 10:36 | |

- ◆ PtN: Input the name of the point to be measured.
- ◆ Code: Input or call up the code.
- ◆ R.Ht: The current prism height.
- ◆ DrctA: Collimate the side of column.
- ◆ DrctB: Collimate the other side of column.
- ◆ Centr: Collimate the center and measure.
 - ◆ [Ok]: Set the angle of Direction A.
 - ◆ [Angle]: Re-measure the angle.
 - ◆ [Dist]: Start to measure the center point.
 - ◆ [ReMe]: Re-measure the distance.
 - ◆ HA: The angles of two sides.
 - ◆ HD: Horizontal distance from instrument center to column surface.
 - ◆ [Save]: Save the measurement result. It should finish two angle and distance measurements.
 - ◆ {Data}: After measuring, the coordinates of center point and measurement result will be displayed.
 - ◆ {Grap}: Display the graphics of center point.

10.5 MLM

•To measure the horizontal distance (dHD), slide distance(dSD), elevation distance(dVD) and horizontal angle (HR) between two prism. Input the coordinate or call up a data file is also available.

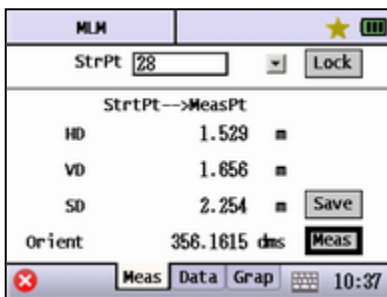
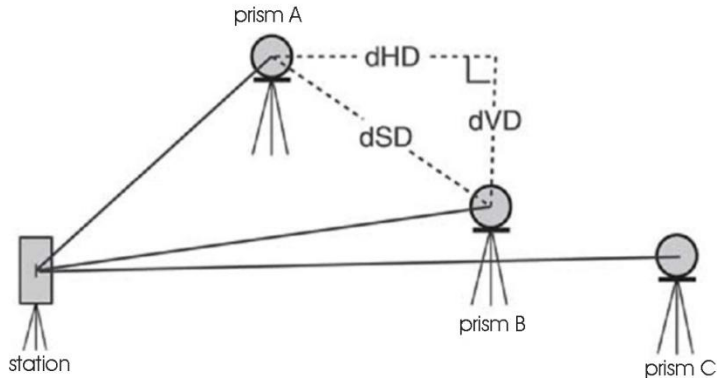

◆ StrPt: Input or call up a known point as the start point. The station point is default.

◆ HD: The horizontal distance between start point and measuring point.

◆ VD: The elevation distance between start point and measuring.

◆ SD: The slide distance between start point and measuring point.

◆ Orient: The bearing angle from start point to measuring point.

◆ [Lock]: Lock the current start point, if not, the start point would be the last measured point.

◆ [Save]: Save the current coordinates of measuring point.

◆ [Meas]: Start to measure.

10.6 Line & Extend Pt

•To calculate the measuring point by measuring two points and inputting the extent distance from start point to end point.

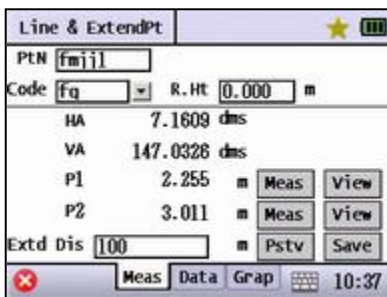
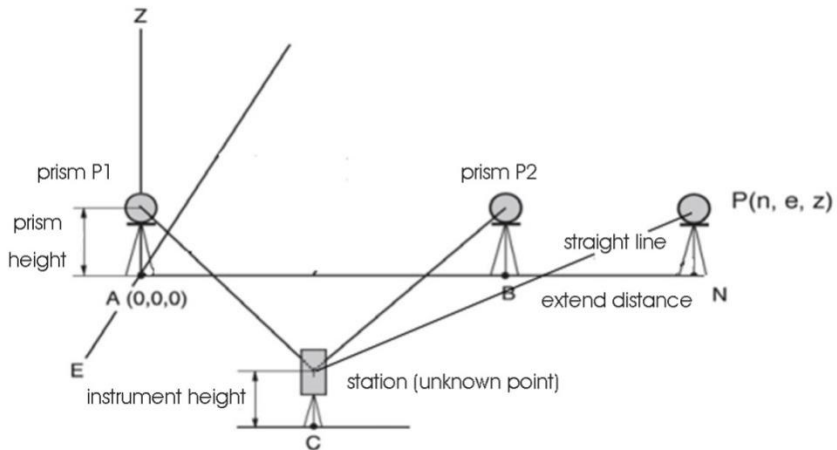

◆ PtN: Names of the point to be measured.

◆ Code: Code of the point to be measured.

◆ R.Ht: The prism height.

◆ HA: The current horizontal angle.

◆ VA: The current vertical angle.

◆ P1: The slide distance to the first measured point.

◆ P2: The slide distance to the second measured point.

◆ Extd Dis: Input the extend distance.

◆ [Meas]: To measure the first or second point.

◆ [View]: To view the measurement result.

◆ [Pstv]: Input the direction of extension line.

◆ [Save]: To save the coordinates of extension point

10.7 Line & AngPt

•To calculate the coordinate by measuring two points and inputting the angle from station to measuring point.

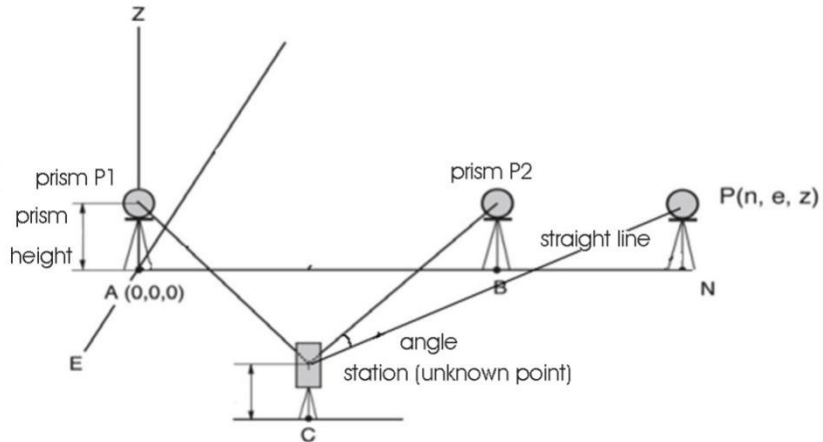

| Line & AngPt | |
|----------------------|------------------------|
| PTN | Fm11 |
| Code | Fq R.Ht 0.000 m |
| HA | 352.5746 dms |
| VA | 147.0307 dms |
| P1 | 3.011 m Meas View |
| P2 | 3.006 m Meas View |
| Orient. | 352.5745 dms Meas Save |
| Meas Data Grap 10:37 | |

◆ PtN: Name of the point to be measured.

◆ Code: Code of the point to be measured.

◆ R.Ht: The prism height.

◆ HA: The current horizontal angle.

◆ VA: The current vertical angle.

◆ P1: The slide distance to the first measured point.

◆ P2: The slide distance to the second measured point.

◆ Orient.: Direction from measured point to the point to be measured.

◆ [Meas]: To measure the first or second point, or the direction of the point to be measured.

◆ [View]: View the coordinates of measured point.

◆ [Save]: To save the coordinates of measured point.

11. STAKE OUT

- User should setup the station before stake out.

Menu of stake out



11.1 Pt SO

- Point stake out. Call up a known point to stake out.



◆ PTN: Name of the stake-out point.

◆ R.Ht: The prism height.

◆ : To call up or input a stake-out point.

◆ [Last]: To call up the last stake-out point.

If the stake-out point is the first one, there will not be any change.

◆ [Next]: To select the next stakeout point.

If the stake-out point is the last one, there will not be any change.

◆ Correct: The current value is correct.

◆ or : Direction to rotate the instrument.

◆ Far & Near: Distance that the prism should move forward or backward.

◆ or : The distance and the direction that the prism is away from the stake-out point.

◆ Fill or Dig: Distance that the prism should move to upward or downward.

◆ HA: Horizontal angle of the stake-out point.

◆ HD: Horizontal distance of the stake-out point.

- ◆ Z: Elevation of stakeout point.
- ◆ [Save]: Save the measurement result.
- ◆ [Meas]: Start to measure.
- ◆ {Data}: Display the measurement result.
- ◆ {Grap}: Display the graphics of the stake-out point, station point and measuring point.

11.2 Ang & Dist SO

● To stake out by inputting the distance, angle and elevation between the station point and the stake-out point.

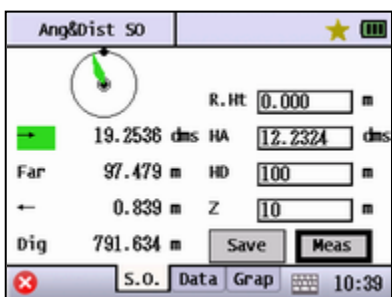

- ◆ R.Ht: The prism height.
- ◆ Correct: The current value is correct.
- ◆ ← or →: Direction to rotate the instrument.
- ◆ Far & Near: Distance that the prism should be moved far or near to the station.
- ◆ ← or →: Distance that the prism should be moved to leftward or rightward.
- ◆ Fill or Dig: Distance that the prism should be moved to upward or downward.
- ◆ HA: Input the horizontal angle of the stake-out point.
- ◆ HD: Input the horizontal distance of the stake-out point.
- ◆ Z: The elevation of stakeout point.
- ◆ [Save]: Save the measurement result.
- ◆ [Meas]: Start to measure.
- ◆ {Data}: Display the measurement result.
- ◆ {Grap}: Display the graphics of the stake-out point, station point and measuring point.

11.3 Alignment SO

- To stake out by input a known point, azimuth, HD and VD.

- ◆ PtN: Input or call up a known point.
- ◆ Azimuth: The azimuth from the known point to the stake-out point.
- ◆ HD: Horizontal distance between the known point and the stake-out point.
- ◆ VD: Elevation distance between the known point and the stake-out point.
- ◆ [Next]: Finish inputting and move to the next step.

- ◆ [Back]: Move back to the previous step.

- To find more detail on "Pt SO".

11.4 Straight Reference Line SO

- The system will calculate the coordinates of the stake-out point through two known points and the offset distance of the line which is formed by these two known points.

- ◆ StrtPt: Input or call up a known point as the start point.
- ◆ End Pt: Input or call up a known point as the end point.
- ◆ ← or →: The left or right offset distance
- ◆ Fore or Back: The backward or forward offset distance.
- ◆ ↑ or ↓: The upward or downward offset distance.
- ◆ [Next]: Calculate the coordinates of stake-out point and go to the next stake-out

interface

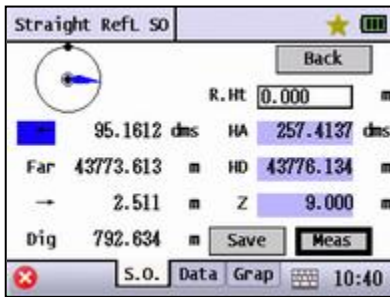

◆ [Back]: Go back to the previous screen.

● Other function keys can refer to "Pt SO".

12. ROAD

In Road program user can carry out the measurement and stakeout with reference to the straight line, circular curve and transition curve. The program can process the coordinates calculation and stakeout according to the chainage and offset distance.

Menu of ROAD

| default | | ★ | ☰ |
|---------|-------------|---|-------------|
| Job | Meas | 1 | Select Road |
| Data | Station | 2 | H Alignment |
| COGO | Collect | 3 | V Alignment |
| Set | StakeOut | 4 | Road SO |
| Adjust | Road | 5 | Road XYZ |

10:43

12.1 Select Road

•Select or create a road to be the current road job. Every road has two elements: horizontal alignment and vertical alignment.

| Select Road | | ☰ |
|-------------|----------------|---|
| Name | Establish Time | |
| egroad | 00/00/00 00:00 | |

New Del Edit

10:43

- ◆New: Create a new road.
- ◆Del: Delete a road.
- ◆Edit: Edit a road.

12.2 H Alignment

| H Alignment | | | ☰ |
|-------------|----------|-------------|---|
| Type | | | |
| StrtPt | 0+0.000 | 2538114.854 | |
| TranCurv | 150.000 | 401.750 | |
| TranCurv | -90.000 | ∞ | |
| Curve | -140.000 | 64.767 | |
| TranCurv | -90.000 | 140.000 | |

Add Del Edit

Data Grap 10:44

- ◆[Add]: Add an element to the horizontal alignment. The first one must be the start point.
- ◆[Del]: Delete a selected element.
- ◆[Edit]: Edit a selected element.
- ◆{Grap}: The plane graphics according to the horizontal alignment data.

●Graphics of horizontal alignment

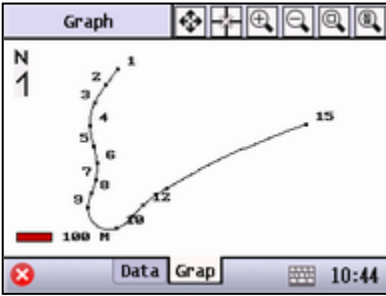

●Horizontal alignment includes the following elements: Start point, straight line, circular curve and transition curve.

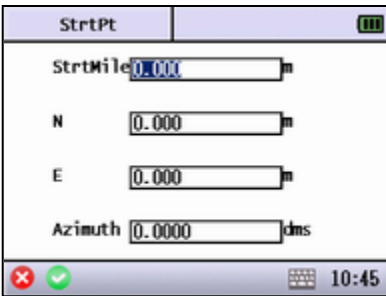

- ◆ StrtMile: The mile of start point
- ◆ N: The north coordinate of start point
- ◆ E: The east coordinate of start point
- ◆ Azimuth: The azimuth of start point

●Input the specification of straight line

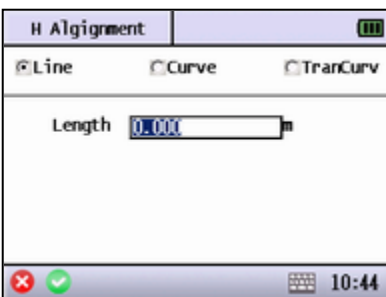
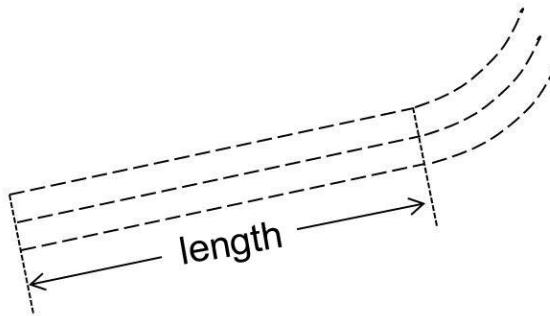

- ◆ Line: Select to input the parameter of straight line.
- ◆ Length: Input the length of straight line, which must be a positive value.

- Input the parameter of circular curve.

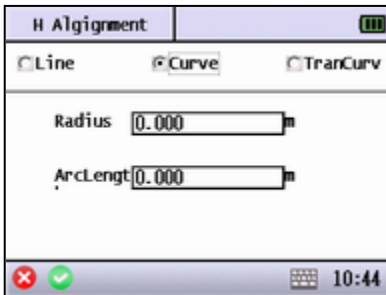
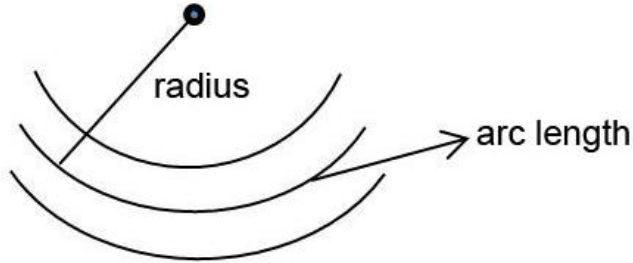

◆ curve: To input the parameter of circular curve.

◆ Radius: Input the radius of circular curve, positive value means turning right, minus value means turning left.

◆ ArcLength: Input the arc length which must be positive.

- Input the parameter of transition curve.

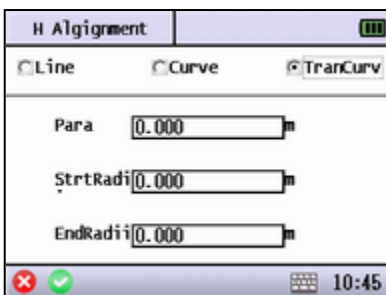
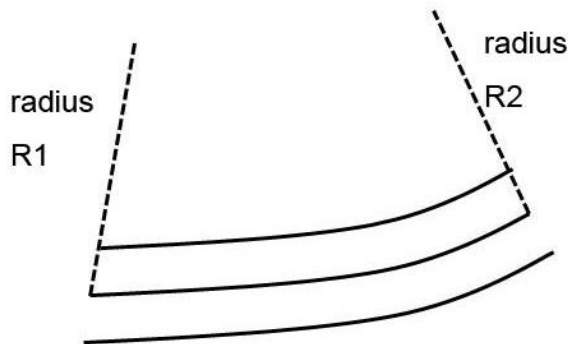

◆ TranCurv: To input the parameter of transition curve.

◆ Para: Input the parameter A of transition curve, positive value means turning left, minus value means turning right.

◆ StrtRadi: Input the start radius R1 which must be positive. While the value is ∞ , for convenience, user just needs to input 0.

◆ EndRadi: Input the end radius R2 which must be positive. While the value is ∞ , for convenience, user just needs to input 0.

12.3 V Alignment

Vertical alignment is composed of cross points which include chainage, elevation and length of the curve. The start point and end curve length must be zero.

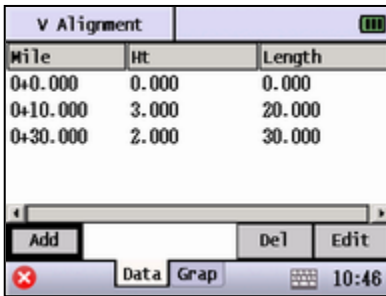
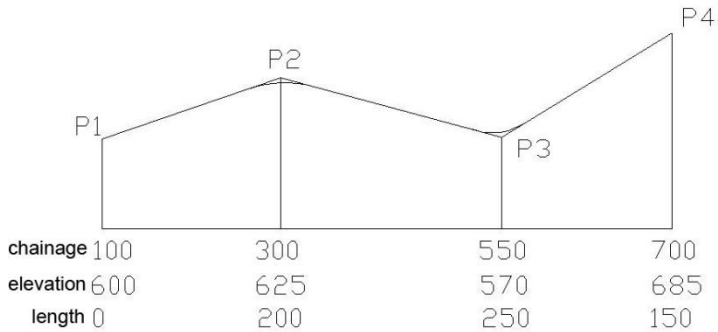

- ◆ [Add]: Add a vertical alignment data.
- ◆ [Del]: Delete a selected alignment data.
- ◆ [Edit]: Edit a selected alignment data.
- ◆ {Grap}: Display the vertical section graphics according to the input vertical alignment data.

● Graphics of vertical alignment.

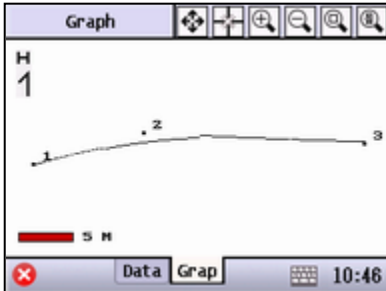

● The point name in the graphics is numbered according to the order of the alignment data.

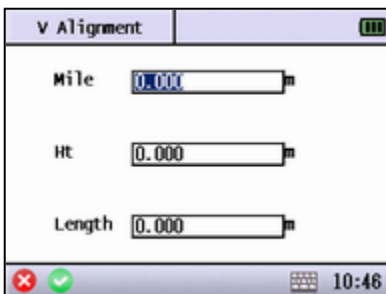

- ◆ Mile: The mile of change point.
- ◆ Ht: The height of change point.
- ◆ Length: The curve length of change point.

12.4 Road SO

- For the road stake out, user should define the horizontal and vertical alignments first with the reference of the last several sessions. (If it does not need to dig or fill, user does need to define the vertical alignment.
- Before road stake out, user should setup the station.

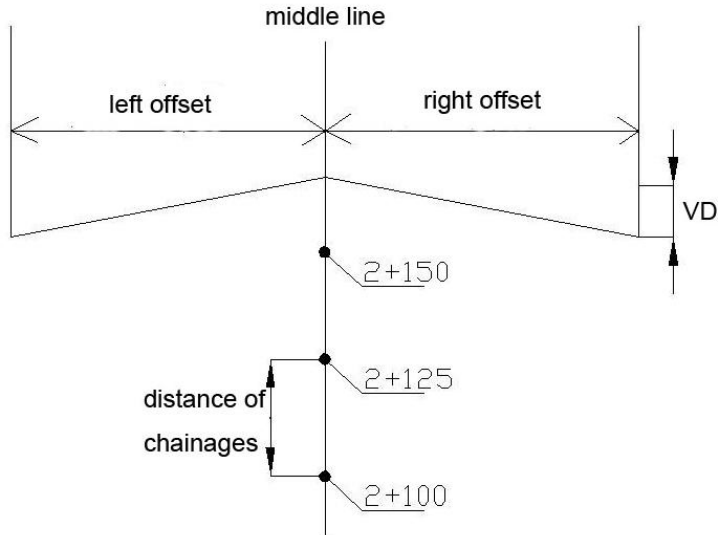

◆ StrtChng: The start chainage of continuous stake-out point.

◆ StepSize: The increased or decreased mile value during stake-out.

◆ ← or →: The left or right offset from the middle line of the road.

◆ ↑ or ↓: The elevation offset of the design point between the stake-out point and middle line of the road.

◆ [Next]: Finish the initial setting and enter to the next stake-out screen.



◆ Chng: The chainage of the current stake-out point.

◆ R.Ht: The prism height.

◆ - : Decrease the chainage according to the stepsize.

◆ + : Increase the chainage according to the stepsize.

◆ XYZ: View the coordinates of the stake-out point after being calculated.

- ◆ Correct: The current value is correct.
- ◆ ←/→: The left or right angle that the instrument should be rotated.
- ◆ Far/Near: The distance the prism should move away or near to the instrument.
- ◆ ←/→: The left or right distance that the prism should move.
- ◆ Fill/Dig: The forward or backward distance that the prism move to.
- ◆ HA: Input the horizontal angle which is to be staked out.
- ◆ HD: Input the horizontal distance which is to be staked out.
- ◆ Z: The elevation of the stake-out point.
- ◆ [Save]: Save the measurement result.
- ◆ [Meas]: Start to measure.
- ◆ {Data}: Display the measurement result.
- ◆ {Grap}: Display the graphics of stakeout point, station point and measuring point.

12.5 Road XYZ

• After setting the horizontal alignment and vertical alignment, the coordinates can be calculated and saved as the coordinates data which can be staked out by Pt SO program.

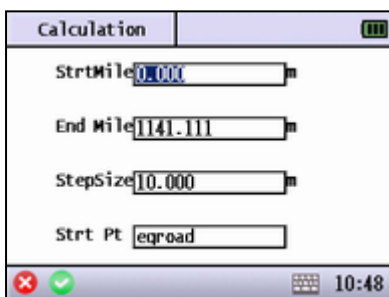

- ◆ StrtMile: The start mile to be calculated.
- ◆ End Mile: The end mile of the calculation.
- ◆ StepSize: The interval value of the point to be calculated.
- ◆ StrtPt: The name of the calculated point. The system will add 1 automatically to the name of the next point.

13. CHECK AND ADJUSTMENT

This instrument has undergone a strict process of checking and adjustment, which ensures that it meets quality requirement. However, after long periods of transportation or under a changeable environment, some influences may occur to the internal structure. Therefore, before the instrument is used for the first time, or before precision surveys, user should be launch check and adjust introduced in this session to ensure the precision of the job.

13.1 Plate Vial

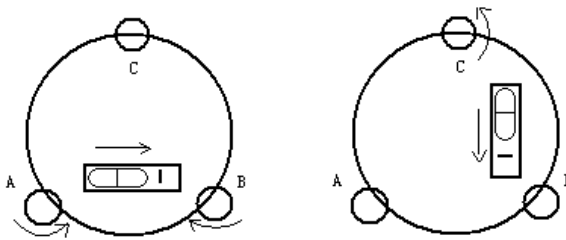

Inspection

Turn the leveling screw A and B to move the bubble in the circular vial, in which case the bubble is located on a line perpendicular to a line running through the centers of the two leveling screw being adjusted. Rotate 90° and turn the leveling screw C to move the bubble to the center of the circular vial. Rotate the instrument to 180° to see whether the bubble is in center, if not, the plate bubble needs to be adjusted.

Adjust

1. If the bubble of the plate vial moves away from the center, bring it half way back to the center by adjusting the leveling screw, which is parallel to the plate vial. Correct the remaining half by adjusting the screw of plate vial with adjusting pin.

2. Confirm whether the bubble is in the center by rotating the instrument 180° . If not, repeat Step 1.

3. Rotate the instrument 90° and adjust the third screw to center the bubble in the vial.

Repeat checking and adjustment steps until the bubble remains in the center with the vial in any direction.

13.2 Circular Vial

Inspection

No adjustment is required if the bubble of circular vial is in the center after checking and adjustment of the plate vial.

Adjust

If the bubble of the circular vial is not in the center, bring the bubble to the center by using the adjusting pin or hexagon wrench to adjust the bubble adjusting screw. First loosen the screw opposite to the offset side, and then tighten the other adjusting screw on the offset side, bringing the bubble to the center. When the bubble stays in the center, keep the tightness of the three screws uniformly.

13.3 Compensator 0 Offset Adjustment

Refer to Session 7.1.

13.4 Inclination of Reticle

Inspection

1. Sight object A through the telescope and lock the horizontal and vertical clamp screws.

2. Move object A to the edge of the field of view with the vertical tangent screw (point A')

3. Adjustment is not necessary if object A moves along the vertical line of the reticle and point A' still in the vertical line.

As illustrated, A' offsets from the center to the cross hair tilts, then need to adjust the reticle.

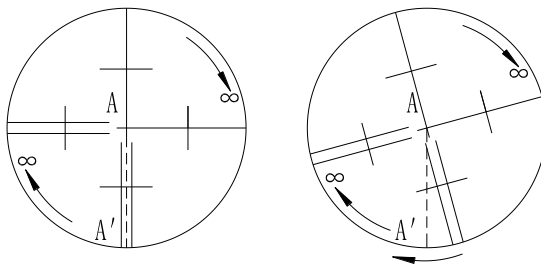

Adjust

1. If the object A does not move along with the vertical line, firstly remove

the eyepiece cover to expose the four reticle adjusting screws.

2. Loosen the four reticle adjusting screws uniformly with an adjusting pin. Rotate the reticle around the sight line and align the vertical line of the reticle with point A'.

3. Tighten the reticle adjusting screws uniformly. Repeat the inspection and adjustment to see if the adjustment is correct.

4. Replace the eyepiece cover.

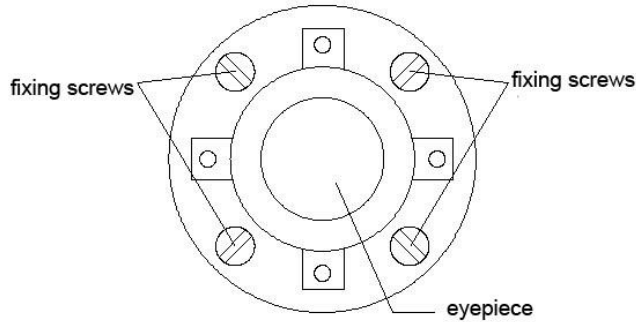

13.5 Perpendicularity of Line of Sight to Horizontal Axis (2C)

Inspection

1. Set object A at a far distance at the same height as the instrument, then level and center the instrument and turn on the power (horizontal angle $L=10^{\circ}13'10''$).

2. Sight object A in left position and read the horizontal angle value (horizontal angle $R=190^{\circ}13'40''$).

3. Loosen the vertical and horizontal clamp screws and rotate the telescope. Sight object A in right position and read the horizontal angle value.

4. $2C = L - R \pm 180^{\circ} = -30'' \geq \pm 20''$, adjustment is necessary.

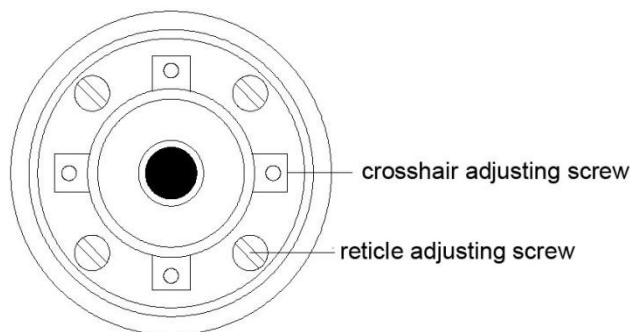

Adjust

1. Use the tangent screw to adjust the horizontal angle reading,

2. Take off the cover of the reticle between the eyepiece and focusing screw. Adjust the two adjusting screws by loosening one and tightening the other. Move the reticle to sight object A exactly.
3. Repeat inspection and adjustment until $|2C| < 20$.
4. Replace the cover of the reticle.

13.6 Vertical Index Difference Compensation

Inspection

1. Mount and level the instrument and make the telescope parallel with the line connecting the center of the instrument to any one of the screws. Lock the horizontal clamp screw.
2. After turning on the power, zero the vertical index. Lock the vertical clamp screw and the instrument should display the vertical angle value.
3. Rotate the vertical clamp screw slowly in either direction about 10mm in circumference, and the error message “b” will appear. The vertical axis has increased to more than 3' at this time and exceeds the designated compensation range.
4. Rotate the above screw to its original position, and the instrument display screen will show the vertical angle again, meaning that the vertical index difference compensation function is working.

Adjust

If the compensation function is not working, send the instrument back to the factory for repair.

13.7 Adjustment of Vertical Index Difference (i Angle) and Setting Vertical Index 0

Please refer to Session 7.2.

13.8 Optical Plummet

Inspection

1. Set the instrument on the tripod and place a piece of white paper with two perpendicular lines, then intersect drawn on it directly under the instrument.
2. Adjust the focus of the optical plummet and move the paper so that the intersection point of the lines on the paper comes to the center of the field of view.
3. Adjust the leveling screws so that the center mark of the optical plummet coincides with the intersection point of the cross on the paper.

4. Rotate the instrument around the vertical axis, and observe whether the center mark position coincides with the intersection point of the cross at every 90° .

5. If the center mark always coincides with intersection point, no adjustment is necessary.

Otherwise, the following adjustment is required.

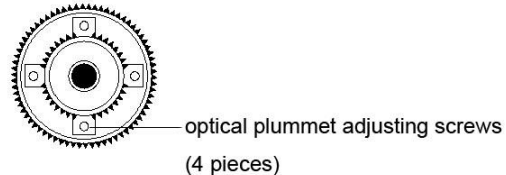
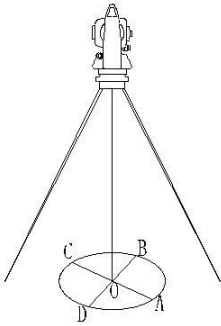

Adjust

1. Take off the protective cover between the optical plummet eyepiece and focusing knob.

2. Fix the paper. Rotate the instrument and mark the point of the center of optical plummet which falls on the paper at every 90° . As illustrated: Point A, B, C, and D.

3. Draw lines that attach AC and BD and mark the intersection point of the two lines as O.

4. Adjust the four adjusting screws of the optical plummet with an adjusting pin until the center mark coincides with Point O.

5. Repeat the inspection and adjusting steps to be sure that the adjustment is correct.

6. Replace the protective cover.

13.9 Laser Plummet

Inspection

1. Set the instrument on the tripod and place a piece of white paper with two perpendicular lines under the instrument.

2. Open the laser plummet, move the paper to make the laser point coincide with the center of two perpendicular lines.

3. Rotate the plummet to make the laser point coincide with the intersection point on the paper.

4. Rotate the instrument, every 90° check contact ratio of laser point and

intersection point.

5. If the laser point always coincided with the intersection point, no adjustment is necessary.

Otherwise, the following adjustment is required.

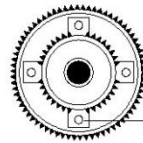
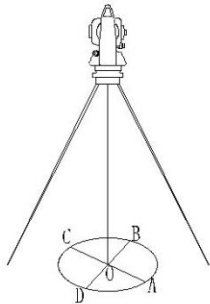

optical plummet adjusting screws
(4 pieces)

Adjust

1. Take off the protective cover
2. Fix the paper and mark the laser point on the paper every 90°. As shown in the picture: Point A, B, C and D.
3. Line the Point AC and BD, the intersection point is O.
4. Use Allen Key to adjust the four adjusting screws to make the center of the laser point coincide with point O.
5. Repeat the inspection and adjusting steps to be sure that the adjustment is correct.
6. Replace the protective cover.

13.10 Instrument Constant (K)

Please refer to Session 7.3.

13.11 Parallelity Between Sight Line and Emitting Photoelectronic Axis

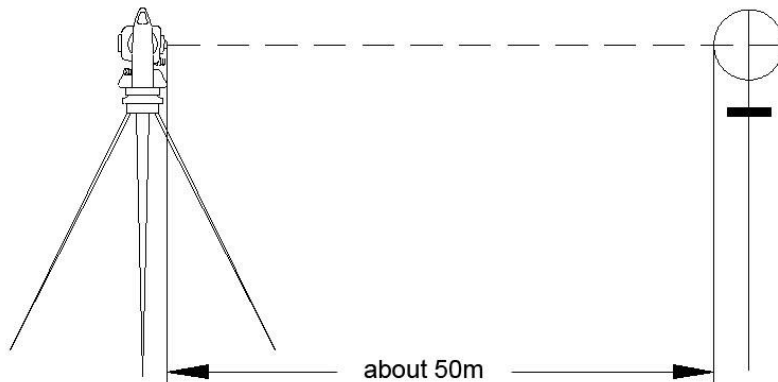

Inspection

1. Set the reflector 50m away from the instrument.

2. Sight the center of the reflector with reticle.
3. Power on and enter Distance Measurement Mode. Press [SD] or [HD] to measure. Rotate the Horizontal Tangent Screw and Vertical Tangent Screw, to do electronic collimation and make the light route of EDM unblocked. In the bight zone find the center of emitting photo electronic axis.
4. Check whether the center of reticle coincides with the center of emitting photo electronic axis. If so, the instrument is up to grade.

Adjust

If there is a great deviation between the center of reticle and the center of emitting photoelectric axis, the instrument should be sent to service department for professional repairing.

13.12 Tribrach Leveling Screw

If any one of the leveling screws becomes flexible, tighten the two adjusting screws on the side of leveling screw appropriately.

13.13 Related Parts for Reflector

1. The Tribrach and Adapter for Reflector

The plate vial and optical plummet in the adapter and plate vial should be checked, refer to Session 13.1.

2. Perpendicularity of the prism pole

As shown in picture in Session 13.8, mark '+' on Point C, place the fine of the prism pole on the Point C and do not move it during the inspection. Place the two feet fine of Bipod on Point E and F on the cross lines. Adjust the two legs to make the bubble on the prism pole centered.

Set and level the instrument on Point A near the cross. Sight fine of Point C with the center of reticle, and fix the Horizontal Clamp Screw. Rotate the telescope upward to make D near the horizontal hair. Flex the prism pole Leg e to make the D in the center of reticle. Then both Point C and D are on the central line of reticle.

Set the instrument on Point B on the other cross lines. Flex the leg F and make point D on the prism pole overlapped with central line of the point C's cross lines.

Through the collimation on Point A and B, the prism pole has been set perpendicular. If then the bubble deviates from the center, adjust the three screws under circular vial to make the bubble centered, refer to Session 13.2.

Check and adjust again until the bubble is in the center of the vial from both directions.

14. SPECIFICATION

| model | RTS-862R/RTS-865R |
|---|---|
| TELESCOPE | |
| image | erect |
| magnification | 30x |
| effective aperture | 45mm (distance meter: 50mm) |
| resolving power | 3" |
| field of view | 1°30' |
| minimum focus | 1.3m |
| telescope length | 152mm |
| ANGLE MEASUREMENT | |
| measuring method | absolute encoding |
| diameter of disk | 79mm |
| minimum reading | 1"/5" |
| detection method | horizontal: dual vertical: dual |
| unit | 360 |
| vertical angle 0° | 360°/400gon/6400mil |
| accuracy | 2"/5" |
| DISTANCE MEASUREMENT | |
| single prism | 3km |
| triple prism | 5km |
| reflecting sheet | 800m |
| Reflectorless (white) ^{※1} | 300m |
| reflectorless (gray scale=0.18) ^{※1} | 200m |
| unit | m/ft |
| accuracy | $\pm(2+2 \times 10^{-6} \cdot d)$ mm ^{※2} w/o prism: $\pm(3+2 \times 10^{-6} \cdot d)$ mm ^{※2} |
| measuring time (initial) | single fine measure: 0.7s; tracking: 0.7s |
| measuring system | basic frequency: 80mhz |
| wave length | 685nm |
| atmospheric correction | auto sensing |
| atmospheric refraction & earth curvature correction | auto correction. k=0.14/0.20 |
| reflector constant correction | auto correction |
| VIAL | |
| circular vial | 8'/2mm |

| model | RTS-862R/RTS-865R |
|--|--------------------------------------|
| plate vial | 30"/2mm |
| COMPENSATOR | |
| system | dual axis photoelectric detection |
| compensating range | ±4' |
| resolving power | 1" |
| OPTICAL PLUMMET (OR INTERNAL LASER PLUMMET) | |
| image | erect |
| magnification | 3x |
| focusing range | 0.3m ~ ∞ |
| field of view | 5° |
| DISPLAY | |
| type | LCD graphics, color and touch |
| INPUT MODE | |
| type | touch screen; alphanumeric keys |
| DATA TRANSFER | |
| RS232 | yes |
| USB interface | yes |
| Bluetooth | yes |
| STORAGE | |
| internal memory(flash & card) | >10000 points or > 20000 coordinates |
| SD card | 2GB SD card as default |
| BATTERY | |
| battery | Ni-H rechargeable |
| voltage | 6v (dc) |
| operating time | up to 8 hours |
| OPERATION ENVIRONMENT | |
| operation temperature | -20°C ~ +50 °C |
| SIZE & WEIGHT | |
| size | 160mm x 150mm x 340mm |
| weight | 5.4kg |

※1 The Kodak Standard Gray Plate which is used to measure the reflected light intensity

※2 Signal interruption, strong hot flashes, moving objects on the optical path will affect the accuracy. While measuring on the transmitted and refractive objects, such as glass and liquid, it will also affect the accuracy.

15. SAFETY GUIDE

15.1 Internal Distance Meter (visible laser)

Warning

The total Station is equipped with an EDM of Laser Class 3A/III a and it is verified by these labels as follows:

There's an indication label "CLASS III LASER PRODUCT" above the vertical clamp screw on Face Left as well as on the Face Right.

The product is classified as Class 3A laser product, according to the standards as follows:

IEC60825-1:2001 "SAFETY OF LASER PRUDUCTS"

The product is classified as Class III a laser product according to the standards as follows:

FDA21CFR ch.1 § 1040:1998 (U.S. Department of Health and Human Services, Code of Federal Regulation)

Class 3A/III a laser product: It is harmful to observe the laser beam continuously. Users should avoid staring at the laser directly. It can reach as much as 5 times the emitting limit of Class 2 / II with a wavelength between 400nm and 700nm.

Warning

It is harmful to continuously look straight at the laser beam.

Prevention

Do not stare at the laser beam, or point the laser beam at others. Reflecting laser beam is also valid.

Warning

When the laser beam emits on prism, mirror, metal surface, window, it might be dangerous to look directly at the reflecting light.

Prevention

Do not stare at the direction which the laser beam is reflected. When the laser is turned on (under distance measure mode), do not look at it near the optical path or the prism. It is only allowed to observe the prism through the telescope of the total station.

Warning

It is dangerous to make improper use of the Class III a laser equipment.

Prevention

To avoid incurring harm, all the users should take safety precautions, and

must make sure that everything is under control within the distance that might bring dangers (according to IEC60825-1:2001)

There are explanations of some principle points of related standard as follows:

Class 3R laser product is used in outdoors and construction site (measuring, defining alignment, levelling).

Such laser equipment can only be installed, adjusted and operated by those persons who have taken related training course and got the authentication.

b Set related laser warning marks on site.

c Prevent anyone from looking straight at the laser beam directly or through optic instrument.

d To avoid the harm brought by laser, users should block the laser beam at the end of the working route. When the laser beam passes through the restricted area (harmful distance*), and there are persons taking activities, users must stop the laser beam in time.

e The optical path of the laser beam should be set higher or lower than the line of sight.

f When the laser instrument is not in use, users should keep it well. It is not allowed for operation unless the user is authenticated.

g. Prevent the laser beam from accidentally emitting at mirror, metal surface, window, etc. Especially pay attention to the surface of plane mirror or concave mirror.

* Harmful distance suggests that the maximum distance from the start point of the laser beam to the point which the laser beam is weakened to a certain degree that doesn't harm people.

The internal distance measure product which is equipped with a Class3R/III a Laser Product has a harmful distance of 1000m (3300ft) . Beyond this distance, the laser strength is weakened to Class I (It is not harmful to look straight at the laser beam).

15.2 Laser Plummet

The internal laser plummet sends out a ray of red visible laser beam from the bottom of the instrument.

This product is classified as Class 2/II laser product.

Class 2 laser product is in accordance with the following standard:

IEC 60825-1:1993 "SAFETY of LASER PRODUCTS"

EN 60825-1:1994+A II :1996 "SAFETY of LASER PRODUCTS"

Class II laser product is in accordance with the following standard:

FDA21CFR ch.1 § 1040:1998 (U.S. Department of Health and Human Services, Code of Federal Regulations)

Class 2/II Laser Product:

Do not stare at the laser beam or point it at others. Users should prevent the laser beam and the strong reflecting light from impinging into eyes so as to avoid incurring harm.

APPEDIX A: DATA FORMAT

Raw Data

| | |
|--------|---|
| JOB | job name, job description |
| DATE | date, time |
| NAME | name of the job creator |
| INST | serial number of the total station |
| UNITS | units in use: m/inch, dms/gon |
| SCALE | grid factor, scale, altitude |
| ATMOS | temperature, pressure |
| STN | station name, instrument height, code |
| XYZ | X (E coordinate), Y (N coordinate), Z (elevation) |
| BKB | backsight point name, backsight angle, azimuth |
| SS | point name, target height, code |
| HV | horizontal angle, vertical angle |
| HD | horizontal angle, vertical angle, height difference |
| SD | horizontal angle, vertical angle, slide distance |
| OFFSET | radial offset, tangential offset, plummet offset |
| NOTE | note |

Coordinates Data

Below is the data formats that are transferred to the computer.

- 1) Pt, N, E, Z, code
- 2) Pt, E, N, Z, code
- 3) Pt, code, N, E, Z
- 4) Pt, code, E, N, Z

Code Data

1) Horizontal Alignment

| | |
|--------|---|
| name | name of the road |
| start | start chainage |
| line | the length of the straight line |
| arc | radius of the circle, length of the curve |
| spiral | radius, length |

2) Vertical Alignment

| | |
|-----|-------------------------|
| gcp | mile, elevation, length |
|-----|-------------------------|

DXF File

Refer to Standard R12.

- 1) All points with the same code will be on the same layer.
- 2) All the lines are on the same layer.
- 3) All points without a code will be on the default layer.